

# ViaLiteHD® – RF Switch Card & Module

## RF Switch Card & OEM Module

- L-Band (700 MHz to 2.45 GHz), GPS or Wideband 10 MHz to 3 GHz
- Low loss and high isolation
- DC switching and pass-through
- Compatible with the Satcom6 outdoor enclosure



The **ViaLiteHD** RF Switch is a 3-port switch that can be used with the **ViaLiteHD** RF splitter/combiner module to provide a 1:1 redundant link in a range of applications including L-Band, GPS and Wideband systems. Together with dual redundant power supplies, the module provides the highest possible availability for a **ViaLiteHD** RF over fiber system. The system can be in a **ViaLiteHD** chassis rack or outdoor enclosure which allows system control via the backplane.

In a typical configuration, an RF signal is split and fed to two transmit modules. These modules are connected via separate optical fibers to two corresponding receiver modules, thus forming primary and secondary paths. The RF outputs of the receivers are connected to the redundancy Switch. The RF output on the common port is fed to the user equipment. The equipment backplane connects the Switch to adjacent modules and ensures that it selects the secondary path in the event of a failure in the primary path. When used with an SNMP controller it is possible to reconfigure the Switch and directly control its functions.

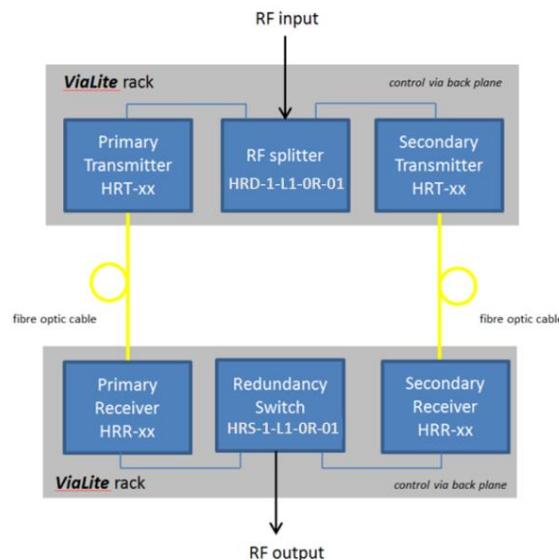

Typical 1:1 redundancy configuration

The Switch allows DC and a 22 kHz tone to be switched from the primary to the secondary path, ensuring continuity of power to the LNB without power level conflicts. The DC and tone switching pass-through allows the LNB to be set and controlled in either high or low band as well as allowing changes in polarization.

## 3-port Switch RF performance characteristics

	L-Band (50 Ω)	L-Band + DC (50 Ω)	Wideband (50 Ω)	Wideband + DC (50 Ω)
Module	HRS-1-L1-01	HRS-4-L1-0R-41	HRS-1-S1-0R-01	HRS-4-S1-0R-41
Frequency Range	700-2450 MHz		10-3000 MHz	
Impedance	(50 Ω)			
VSWR (typ)*	1:1.3	1:1.4	1:1.5	
Max input signal	+24 dBm			
Insertion loss (typ)	1.8 dB	2.3 dB	10-50 MHz – 2.0 dB 50-1000 MHz – 1.7 dB 1000-3000 MHz – 2.5 dB	10-50 MHz – 3.0 dB 50-1000 MHz – 2.5 dB 1000-3000 MHz – 3.0 dB
Isolation (typ)	60 dB	60 dB	10-50 MHz – 70 dB 50-1000 MHz – 70 dB 1000-3000 MHz – 60 dB	
Flatness full band (typ)	±0.3 dB	±0.4 dB	±0.5dB	±0.6 dB
DC pass-through max current	-	0.8 A (fused)	-	0.8 A (fused)
Operating temperature	-20 °C to +60 °C			
Storage temperature	-40 °C to +70 °C			

\* Tested at 1.2 GHz

## Product configurator

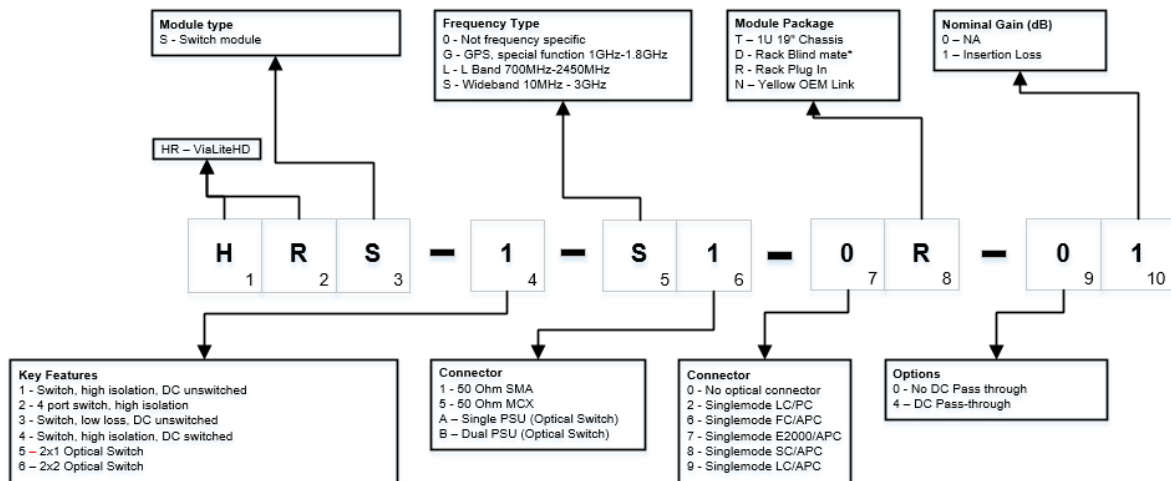

## Popular Products

**HRS-1-L1-0R-41**  
L-Band Switch Module 700 – 2450 MHz, 50 Ohm SMA, Rack plug-in module

**HRS-1-L3-0R-01**  
L-Band Switch Module 700 – 2450 MHz, Rack plug-in module

## Mechanical dimensions

