

ViaLiteHD **SNMP and Web Controller Module**

User Guide

HRC-1-HB-6

CR4645

10/12/2020



Instrument Care and Safety Information

Please read the whole of this section before using your **ViaLiteHD** product. It contains important safety information and will enable you to get the most out of your Fibre Optic Link.

Electrical Safety



The **ViaLiteHD** chassis is a Safety Class 1 product (having metal chassis directly connected to earth via the power supply cable).

When operating the equipment note the following precautions:

- Hazardous voltages exist within the equipment. There are no user serviceable parts inside; the covers should only be removed by a qualified technician.
- There are no user replaceable fuses in the chassis mounted equipment. Replacement should only be carried out by a PPM technician.
- The chassis earth stud SHOULD be connected to the safety earth.
- When using a 2 pin power supply cable the chassis earth stud MUST be connected to the safety earth.
- The **ViaLiteHD** Power Supply Modules do not have an isolating switch on the mains voltage inlet. For this reason, the **ViaLiteHD** Chassis must be installed within easy reach of a clearly labelled dual pole mains isolation switch, which supplies the equipment.

ESD Precautions

The **ViaLiteHD** RF Fibre Optic Link is equipped with high frequency active electronics, without the correct handling they will be susceptible to damage.



Precautions for handling electro-static sensitive devices should be observed when handling all **ViaLiteHD** modules. Technicians should ensure that they use effective personal grounding (i.e. ESD wrist strap etc.) when servicing the equipment. Any equipment or tools used should be grounded to prevent static charge build-up. Good practice should be observed at all times for reference see relevant standards.

EN 61340-5-1, "Protection of Electronic Devices from Electrostatic Phenomena – General Requirements"

Optical Safety



The **ViaLiteHD** RF Fibre Optic Transmitters, Dual Transmitters and Transceivers contain optical sources (usually laser diodes) operating at nominal wavelengths of 1270nm to 1610nm.

These devices are rated as EN60825-1 as CLASS 1 radiation emitting devices. A class 1 laser is safe under all conditions of normal use.

When operating the equipment note the following precautions:

- Never look into the end of an optical fibre directly or by reflection either with the naked eye or through an optical instrument.
- Never leave equipment with radiating bare fibres – always cap the connectors.
- Do not remove equipment external covers when operating.

Table of contents

1	INTRODUCTION.....	5
1.1	Internal architecture	5
1.2	Typical deployment	6
1.3	Care of fibre optic connectors	6
1.4	<i>ViaLiteHD</i> and <i>ViaLite</i> Classic compatibility	6
1.4.1	<i>ViaLiteHD</i> and <i>ViaLite</i> classic compatibility, Ethernet copper RJ45 ports	6
1.4.2	<i>ViaLiteHD</i> and <i>ViaLite</i> classic compatibility, Ethernet optical ports	7
2	<i>VIALITEHD</i> SPECIAL HARDWARE AND SOFTWARE FEATURES	8
2.1	Plug and play, default set up	8
2.2	Web based graphical user interface	8
2.3	System robustness	8
2.4	SNMP functionality	8
2.5	Slot auto configuration	8
2.6	System report	8
2.7	FTP download of new software image for SNMP and web controller	8
2.8	Real time clock	9
2.9	Non-volatile event history log	9
2.10	Summary alarm relay	9
2.11	On-board fast Ethernet switch	9
2.12	On-board temperature sensor	9
2.13	Automatic, software and manually controlled gain	9
2.14	GPS mode operation	10
2.14.1	GPS transmitter mode operation	10
2.14.2	GPS receiver mode operation, units equipped with GPS load simulator	10
2.15	Use definable name fields for both individual modules and chassis	10
3	SNMP AND WEB CONTROLLER MODULE, PHYSICAL INTERFACES.....	12
3.1	Module operation, 7HP standard plug-in module	12
3.2	Fibre optic cable & connectors	13
3.2.1	Connector and cable types	13
3.2.2	Connecting and disconnecting	13
3.2.3	Cleaning optical connectors, cleaning before every use	13
3.2.4	Cleaning optical connectors, high levels of contamination	13
3.2.4.1	FC/APC.....	13
3.2.4.2	SC/APC.....	14
3.2.5	Minimum Bend Radius	14
3.3	Front panel	15
3.3.1	Front Panel Indicators, plug in modules	15
3.3.2	RJ45 Indicators, plug in modules	15
3.3.3	Front panel craft port and reset switch	15
3.4	Rear panel	16
3.4.1	Rear panel, connecting two SNMP and web controller via the fibre ports	16
4	SETTING UP THE SNMP AND WEB CONTROLLER MODULE	17
4.1	Connecting the Module	17
4.2	Setting the IP address and serial interface	17
4.3	Configuring chassis slot positions	22
4.4	Setting SNMP protocol community names	22
5	CONNECTING TO THE SNMP AND WEB CONTROLLER.....	23
5.1	Computer software environment	23
5.2	Computer IP configuration	23
5.3	User access levels and passwords	25
5.4	Setting user access passwords	25
5.5	Other telnet commands	27
6	USING THE WEB CONTROL INTERFACE	28
6.1	Box control conventions	28
6.2	Opening the web the graphical user interface with a web browser	28
6.3	Graphical user interface, introduction screen	28
6.4	Top bar	28
6.5	Left side bar	29
6.5.1	Left side bar – System view	29
6.5.1.1	Left side bar – System view, properties	30
6.5.1.2	Left side bar – System view, properties, changing values	30
6.5.1.3	Left side bar – System view, inventory.....	30
6.5.1.4	Left side bar – System view, configuration	31
6.5.1.5	Left side bar – System view, environment.....	31
6.5.1.6	Left side bar – System view, thresholds.....	32
6.5.1.7	Left side bar – System view, time and date.....	33
6.5.1.8	Left side bar – System view, commands	33
6.5.2	Left side bar – Management	34
6.5.3	Left side bar – System report	35
6.5.3.1	Left side bar – System report, format, header and System Data	36
6.5.3.2	Left side bar – System report, format, module table.....	36
6.5.3.3	Left side bar – System report, format, module data.....	36
6.5.3.4	Left side bar – System report, generating a system report	37

	6.5.3.5	Left side bar – System report, generating an Event report	37
	6.5.4	Left side bar – Software update	37
6.6		Bottom event window	37
	6.6.1	Bottom event window, event sorting	38
	6.6.2	Bottom event window, event severity	39
		*Voltage feed alarm user settable, minor by default.	40
6.7		Central chassis graphical interface window	41
7		SLOT WINDOWS.....	42
	7.1	Slot windows general information	42
	7.1.1	Slot windows general information, opening the slot window	42
	7.2	Slot windows for TX type	42
	7.2.1	Slot window for TX type, monitoring	43
	7.2.1.1	Slot window for TX type, monitoring, note on TX AGC	43
	7.2.2	Slot window for TX type, control	44
	7.2.2.1	Slot window for TX type, control, gain control priorities	44
	7.2.2.2	Slot window for TX type, control, enabling and disabling the laser	44
	7.2.2.3	Slot window for TX type, control, turning on and off FSK.....	44
	7.2.2.4	Slot window for TX type, control, turning on SGC and setting the soft gain	45
	7.2.2.5	Slot window for TX type, control, turning on AGC and setting the AGC target	45
	7.2.2.6	Slot window for TX type, control, calculating AGC target level	45
	7.2.2.7	Slot window for TX type, control, enabling and disabling GPS mode.....	46
	7.2.3	Slot window for TX type, advanced	46
	7.3	Slot windows for TX type (DWDM)	47
	7.3.1	Slot Window for TX type (DWDM), Monitoring	47
	7.3.2	Slot Window for TX type (DWDM), Control	48
	7.4	Slot windows for RX type	48
	7.4.1	Slot window for RX type, monitoring	49
	7.4.1.1	Slot window for RX type, monitoring, note on RX AGC modes	49
	7.4.2	Slot window for RX type, control	50
	7.4.2.1	Slot window for RX type, control, gain control priorities	50
	7.4.2.2	Slot window for RX type, control, turning on SGC and setting the soft gain	50
	7.4.2.3	Slot window for RX type, control, turning on AGC and setting the AGC target.....	51
	7.4.2.4	Slot window for RX type, control, calculating AGC target level, RLL mode	51
	7.4.2.5	Slot window for RX type, control, turning on and off FSK	51
	7.4.2.6	Slot window for RX type, control, enabling and disabling GPS mode	51
	7.4.3	Slot window for RX type, advanced	52
	7.5	Slot windows for LNB type	53
	7.5.1	Slot windows for LNB type, LNB	53
	7.5.1.1	Slot windows for LNB type, LNB, changing mode	54
	7.6	Slot windows for Serial Data type	54
	7.6.1	Slot Windows for Serial Data type, Monitoring	55
	7.6.2	Slot Windows for Serial Date type, control	55
	7.7	Slot windows for RF switch type	56
	7.7.1	Slot windows for RF switch type, monitoring	56
	7.7.2	Slot windows for RF switch type, control	57
	7.7.2.1	Slot windows for switch type, change mode	57
	7.8	Slot windows for Splitter type	58
	7.9	Slot windows for Frequency source type	58
	7.10	Slot windows for Redundancy load type	58
	7.11	Slot windows for Amplifier type	58
	7.11.1	Slot window for Amplifier type, monitoring	59
	7.11.2	Slot window for Amplifier type, control	60
	7.11.2.1	Slot windows for Amplifier type, alarm threshold example	60
	7.11.2.2	Slot windows for Amplifier type, change AGC mode	60
	7.11.2.3	Slot windows for Amplifier type, change control values	61
	7.11.3	Slot window for Amplifier type, advanced	61
	7.12	Slot Window for Ethernet type	62
	7.12.1	Slot Window for Ethernet type, Monitoring	62
8		SOFTWARE UPDATE	63
	8.1	Software Update – GUI Method	63
	8.2	Software Update – Serial Cable Method	64
9		SYSTEM INTEGRATION	65
	9.1	Initial set up equipment	65
	9.2	Site requirements	65
	9.3	Other considerations, RJ45 interconnection	65
	9.4	ViaLiteHD trap file	65
10		MECHANICAL DIMENSIONS	66
11		PART NUMBERING	67
12		TECHNICAL SPECIFICATIONS	68
13		MAINTENANCE AND FAULT-FINDING GUIDE	69
14		GLOSSARY	70
15		PRODUCT WARRANTY	71
16		FCC APPROVAL	72

1 Introduction

The **ViaLiteHD** SNMP and Web controller module is used to manage **ViaLiteHD** equipment, both monitoring and controlling modules. It offers multiple switched 10/100 BaseT copper RJ45 Ethernet interfaces at front and rear and may optionally have a rear 100 BaseF optical interface. It sequentially polls all connected modules to monitor status and send commands.

The on board PowerPC runs SNMP firmware that is responsible for monitor, control and updating of the connected module database. It also provides an interface to SNMP manager entities. The SNMP firmware provides an interface to the GUI Java applet, the GUI provides a web based graphic user interface which is displayed on your PC.

The module also provides a single dry contact relay accessible via the chassis connector.

1.1 Internal architecture

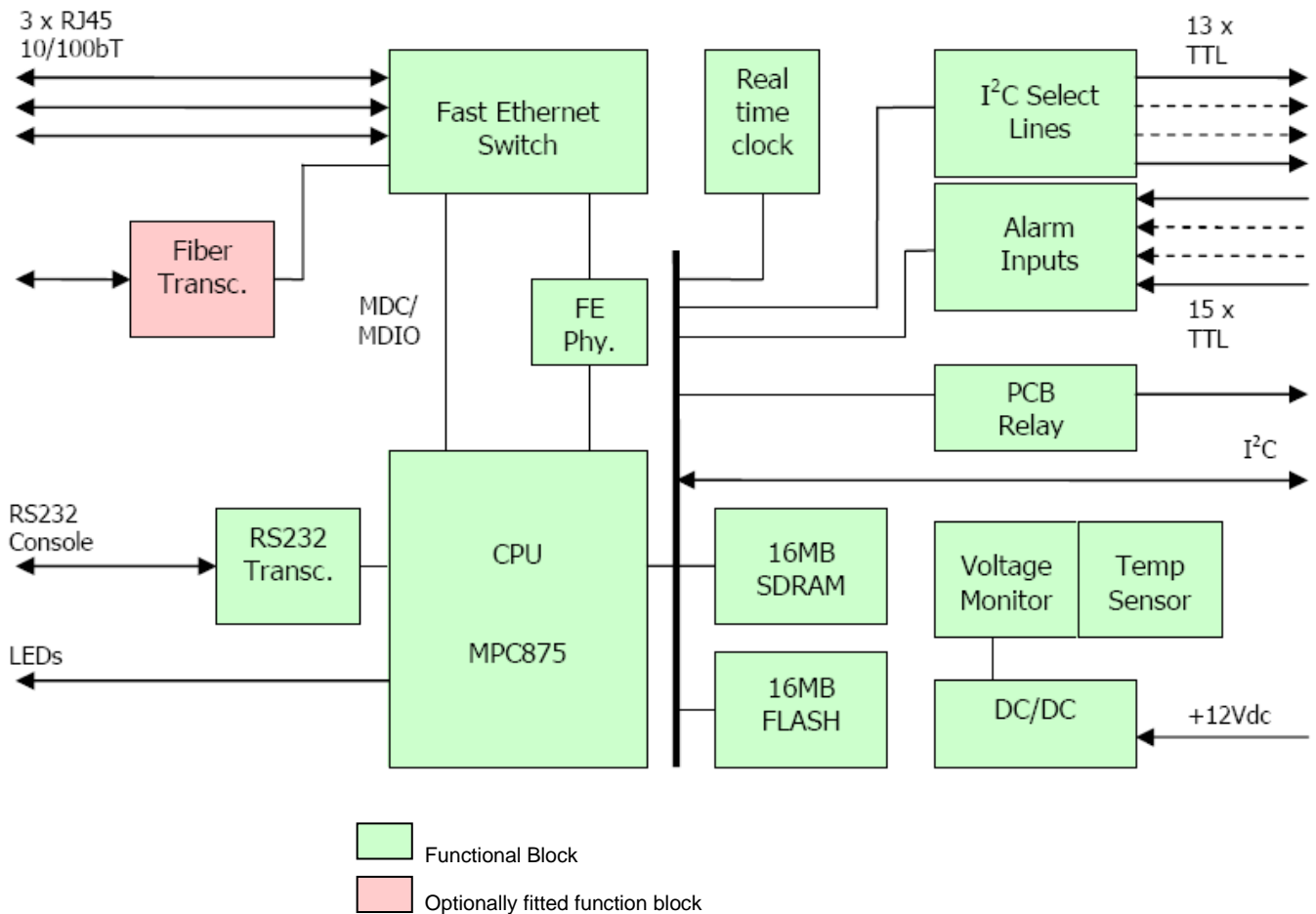

Key features are:

- The Main CPU is a PowerPC running at 133MHz.
- The DC input power feed (+12 volts) is protected by a set resettable fuse, which will only open if subject to fault currents.
- The internal 3.3V is generated by a switch mode power converter running at approximately 320kHz.
- The internal 5V is generated by a switch mode power converter running at approximately 1MHz.
- Other internal voltages are generated from low drop out linear regulators.
- The faster Ethernet switch has an external clock of 25MHz and an internal clock of 125MHz.
- The fibre transceiver is low power class 1 and safe under all normal operating conditions.
- The Real time controller has a calendar accurate to 2099 and is clocked at 32kHz.
- The Real time clock is backed up with a super capacitor that has a typical hold up time of more than 10 days.
- The temperature sensor reports the board temperature.
- A single dry contact relay accessible via the chassis connector.

1.2 Typical deployment

The SNMP and Web controller module is typically deployed as part of a 3U chassis based equipment solution. It can however be fitted in a range of other equipment.

When fitted in an HRK3 chassis it must be fitted in slot 14, this is the only slot to have communication with all other slots.

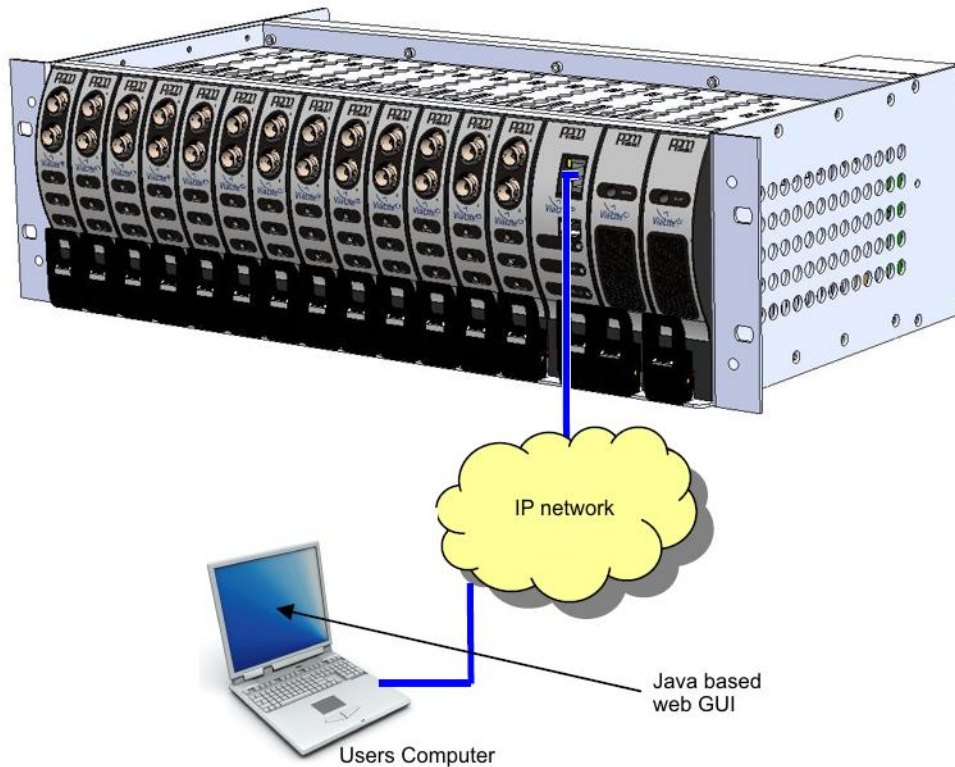

1.3 Care of fibre optic connectors

When the fibre optic cables are not connected, it is essential that the cable and equipment connectors are protected by the Dust Caps provided with the system. Failure to do so may result in damage to the fibre ends, which are critical to the system performance. Please refer to section 3.2 for fibre optic cable handling details.

1.4 ViaLiteHD and ViaLite Classic compatibility

The **ViaLiteHD** SNMP and Web controller module will not control or monitor **ViaLite Classic** equipment.

The 10/100 BaseT copper RJ45 interface may be attached to **ViaLite Classic** equipment to provide a switching function. The 100 BaseF optical interface may be connected to **ViaLite Classic** Ethernet 100Mb/s Optical Transceiver.

1.4.1 **ViaLiteHD and ViaLite classic compatibility, Ethernet copper RJ45 ports**

Family	Function	ViaLite Classic			ViaLiteHD		Interface type
		SNMP	Ethernet 100BT	Ethernet 1000BT	SNMP	Ethernet 1000BT	
ViaLite Classic	SNMP	✓	✗	✓	✓	✗	10 BaseT
	Ethernet 100BT	✗	✓	✓	✓	✗	100 BaseT
	Ethernet 1000BT	✓	✓	✓	✓	✓	10/100/1000 BaseT, switchable
ViaLiteHD	SNMP	✓	✓	✓	✓	✗	10/100 Base T, switchable
	Ethernet 1000BT	✗	✗	✓	✗	✓	1000 BaseT

1.4.2 ViaLiteHD and ViaLite classic compatibility, Ethernet optical ports

Family	Function	ViaLite Classic			ViaLiteHD		Interface type
		SNMP	Ethernet 100BT	Ethernet 1000BT	SNMP	Ethernet 1000BT	
ViaLite Classic	SNMP	x	x	x	x	x	No fibre interface
	Ethernet 100BT	x	✓	x	✓	x	100BaseF
	Ethernet 1000BT	x	x	✓	x	✓	1000 BaseF
ViaLiteHD	SNMP	x	✓	x	✓	x	100BaseF
	Ethernet 1000BT	x	x	✓	x	✓	1000 BaseF

2 ViaLiteHD special hardware and software features

When using the *ViaLiteHD* SNMP and web controller it makes a number of special software and hardware features available to its users.

2.1 Plug and play, default set up

The SNMP and web controller module comes fully programmed and configured, it is ready to work with a default IP address. You should check both with your network administrator that this address is valid for your LAN and you are able to access it from your computer. Below are the factory default set ups.

Default serial port password	web4270	
Default telnet port password	NOT SET	By default this is disabled; see section 5.4
Default FTP password	web4270	
Default web GUI address	10.0.0.104	Use http://10.0.0.104 in your web browser
Default web GUI	See section 5.3	
Default SNMP GET community	public	only user settable in 10.4.51 and above
Default SNMP SET community	private	only user settable in 10.4.51 and above

The module maybe reprogrammed, if desired. Full details are given in this handbook in sections 4 and 5. Details are also given in section 5.2 on how to configure your computer.

2.2 Web based graphical user interface

The module provides a graphical user interface (GUI) Java applet, the GUI provides a web based interface which is displayed on your PC. The GUI will run on a java enabled web browser and allows you to control and monitor the chassis. The GUI is password protected; it has three different levels of access. The passwords for different access levels can be set by you see section 5.3.

2.3 System robustness

The *ViaLiteHD* chassis does not require that the SNMP card is either fitted or running to provide full analogue functionality of the cards fitted. All modules fitted in the chassis can run independently, once configured.

2.4 SNMP functionality

The module is able to support SNMP functionality and is supplied with an MIB.

2.5 Slot auto configuration

The set-up of every module in the chassis is stored not only in the module, but also on board the SNMP and web controller. This allows the controller to remember the configuration of every module in the chassis.

If "Auto slot config" is enabled the following will happen:

- All module set up data is stored on the SNMP and web controller when the module is recognised.
- When a module is removed the SNMP and web controller will remember what type of module was in each chassis position.
- When a new module is inserted into a vacant slot the SNMP and web controller compares the new module type with the former module type (i.e. Transceiver etc...).
- If this is the same and "Slot auto config" is enabled the controller will up load the former module's configuration to the new module.
- If the new module's type does not match the former module type, no changes will be made to the new module.

If "Auto slot config" is disabled the following will happen:

- The controller will make no changes; it will however store the new module configuration if you wish to enable this feature later.

Auto configuration will take a minimum of two chassis polling cycles (approximately 15 seconds) to be effective. Auto slot configuration settings will be preserved during a system reset.

2.6 System report

This is a tool that allows you to run a report on the chassis and save it as an HTML file. See section 6.5.3 for more details.

2.7 FTP download of new software image for SNMP and web controller

This allows you to update the SNMP and web controller software via FTP. The software update will load a single object containing the operational firmware, graphical user interface (GUI) and management interface browser (MIB). For more details see section 8.

2.8 Real time clock

The SNMP and web controller is equipped with a real time clock. This will continue to run after power is removed from the board. It has a built in calendar with leap year correction up to 2099, and is backed up with a super capacitor, which should give at least 10 days of hold up between charges.

2.9 Non-volatile event history log

A history of the last 128 events is stored in non-volatile memory on the SNMP and web controller. Each event has an index number. This number will increment with each new event. The index number is only reset (to 1) when the event log is cleared. Only the last 128 events are stored, earlier events are erased. See section 6.6 for more details.

2.10 Summary alarm relay

The SNMP and web controller provides a summary alarm relay. The module has a volt free 3-pin connection; this is available on the chassis connector. The three connections are Normally Open (NO), Common (COM) and Normally Closed (NC).

Condition 1 - Power applied to chassis, no alarms (i.e. normal condition):

- Pin NO is open circuit.
- Pin NC is connected to COM.

Condition 2 - Power removed from chassis and/or one or more module alarms (i.e. Alarm condition):

- Pin NO is connected to COM.
- Pin NC is open circuit.

2.11 On-board fast Ethernet switch

The SNMP and web controller is equipped with a managed on board fast Ethernet switch. This supports three copper 10/100 BaseT Ethernet ports and the one optional 100BaseF.

All of the copper ports auto negotiate and are rate switchable.

Pin	SNMP controller function	Direction	Comment
1	Ethernet TX+	Output	IP/LAN communication
2	Ethernet TX-	Output	IP/LAN communication
3	Ethernet RX+	Input	IP/LAN communication
4	Not Used	NA	Terminated on board
5	Not Used	NA	Terminated on board
6	Ethernet RX-	Input	IP/LAN communication
7	Not Used	NA	Terminated on board
8	Not Used	NA	Terminated on board

The fibre port must be correctly physically connected (RX to TX) with a suitable 100BaseF transceiver to function correctly.

The optical and copper ports may be used to provide connectivity to other SNMP and web controllers and peripheral customer equipment.

2.12 On-board temperature sensor

The module is equipped with an on board temperature sensor that reports the temperature of the SNMP and web controller module.

2.13 Automatic, software and manually controlled gain

The *ViaLiteHD* SNMP module allows the selection of three different gain control modes; AGC (Automatic Gain Control), SGC (Software Gain Control), and MGC (Manual Gain Control). They are defined as follows.

- MGC allows the gain of each module to be set using the DIP switches on the base of the card, with the overall gain calculated by subtracting the value of the switches from the maximum gain of the module. This is not an SNMP function. This overrides any AGC or SGC setting applied in software.
- AGC allows the controller in the transmitter or receiver to automatically adjust to give an overall link gain, utilising a closed loop control system, with either the RF input (on transmitters), RF output or received light level (on receivers) as a reference. This setting overrides any SGC setting already applied.
- SGC allows the same level of control as the MGC, but with remote control via the SNMP interface.

NOTE: The use of AGC can mask issues such as dirty optical connectors and degraded or damaged cables. If used, ensure that proper handling procedures are observed for optical connectors.

2.14 GPS mode operation

Note: If your module is not a GPS specific module, this setting will have no effect.

ViaLiteHD offers a range of modules that can support GPS band signals. It also offers software to mimic the operation of copper connected GPS units. Special GPS band units are equipped with hardware that can provide special GPS functions. They will mimic the operation of an active GPS amplifier through the fibre optic link, allowing alarm status on the remote GPS antenna and LNA to be reported.

2.14.1 GPS transmitter mode operation

Under normal no fault condition a GPS TX FOL will operate in an identical fashion to all other **ViaLiteHD** modules. However the transmitter is equipped with additional hardware that detects the DC current flowing from GPS transmitter RF input, to the active GPS antenna.

If the current sunk by the active antenna falls below an alarm threshold (i.e. in the case of the LNA failing or not being connected). The unit will generate an internal alarm. With GPS mode enabled, the transmitter laser will turn off. This will generate an alarm in the connected receiver module, as the connected unit will have a received light level alarm (RLL). The GPS mode can only be enabled and disabled when the unit is under software control. Modules will be delivered with GPS mode ENABLE. Regardless of GPS mode setting, a Vialite GPS transmit module will always have a live LNA feed on the RF port.

2.14.2 GPS receiver mode operation, units equipped with GPS load simulator

Under normal no fault condition a GPS RX FOL operates very similarly to a normal **ViaLiteHD** FOL. With GPS mode enabled, in no fault condition it presents a DC load at its RF output to mimic a connected GPS antenna.

When the unit is in a fault condition; either by way of an internal fault, or due to low received light levels from the connected transmitter, it will disable the current sink. For most GPS receivers this will provide a basic alarm function.

Modules will be delivered with GPS mode enabled. If GPS mode is disabled the DC load will be open circuit in both alarm and non-alarm modes. The GPS mode can only be enabled and disabled when the unit is under software control.

2.15 Use definable name fields for both individual modules and chassis

The chassis has two user definable fields (Name and Location) that may be used to store text information. Each field maybe up to 30 characters in length, this data is stored in the non-volatile memory of the SNMP and web controller. More details are given in section 6.5.1.1.

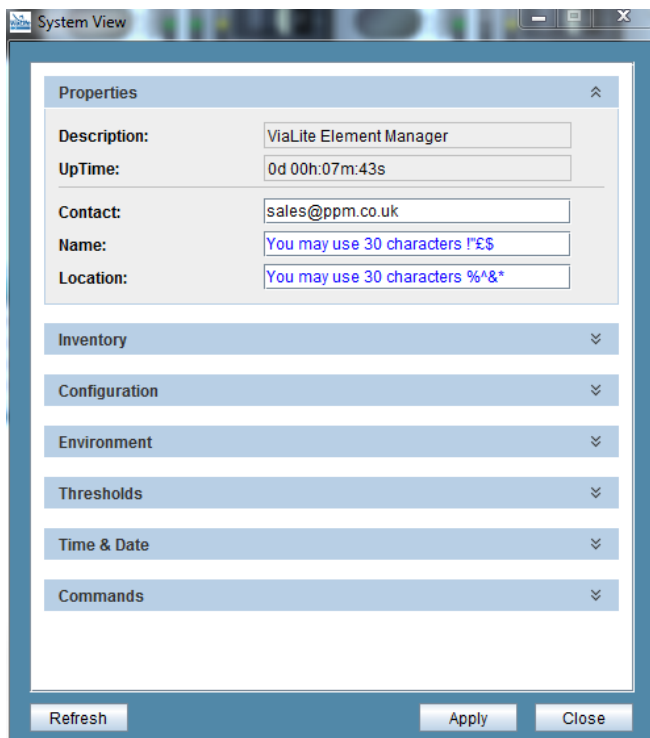

Each module position has one user definable field (Name) that may be used to store text information on the chassis slots. This may be up to 32 characters in length; this data is stored in the non-volatile memory of the SNMP and web controller. The text stored is associated with slot position and will not change if the slot module is changed.

Slot 1 - HRT-G1-8D-10-S1310

General

Part Number:	HRT-G1-8D-10-S1310
Type:	Transmitter
FW Part Number:	ViaLiteHD 82011
FW Version:	120
FW Date:	25 Apr 14
Serial Number:	SN1240264
OEM Number:	T1
Customer ID:	None
Life Counter[H]:	48 Hours [2 Days 0 Hour]
Name:	You may use 32 characters !@#\$%^

Monitoring

Control

Refresh Apply Close

3 SNMP and Web controller module, physical interfaces

This section describes the connections between your *ViaLiteHD* Modules and the SNMP and Web controller module. There is no need to install any interface cables between SNMP and Web controller module and connected modules, as these are all connected via the chassis backplane. Please read fully all relevant documents for information on installing your *ViaLiteHD* equipment before commissioning your system.

3.1 Module operation, 7HP standard plug-in module

All *ViaLiteHD* plug-in modules are hot-swappable, so it is not necessary to power-down the chassis before inserting a module. All optical and Ethernet connectors are retained by the module. So it is necessary to either disconnect any cables or have a sufficiently long service loop.



To install a 7HP Standard module:

- The protective covers on the connectors may be left in place.
- Push the release button of the module handle down and simultaneously pull the top of the handle forwards.
- Align the module upright and perpendicular to the front face of the chassis so that the PCB slides into the “crow’s feet” card guides top and bottom.
- Gently push the module down its guide, applying pressure via the handle, you may also apply pressure between the LED and craft port.
- As the module is fully mated the top of the handle should snap back and lock in position.
- The pawls of the handle should be fully engaged in the matching slots.
- If power is applied to the chassis the module power LED should light as soon as the module is fully inserted.
- Remove protective covers and connect any interface cables.

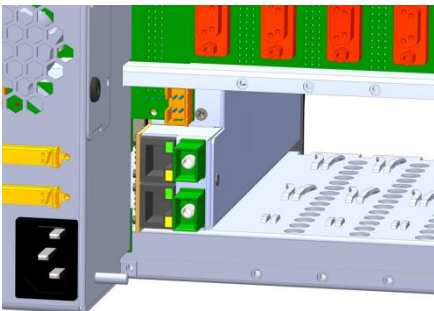

To remove a 7HP Standard module:

- Disconnect any cables if necessary
- Push the release button of the module handle down and simultaneously pull the top of the handle forwards.
- Apply pressure via the handle and gently withdraw the module from the chassis.

3.2 Fibre optic cable & connectors

3.2.1 Connector and cable types

All **ViaLiteHD** SNMP and Web controller module uses singlemode (9µm/125µm) cable terminated in a range of optical connectors detailed below. Cross-site fibre optic cables are available from PPM as either standard patch leads or heavy-duty multicore cables.

Warning! Angle polished (APC) and standard (PC) connector must not be confused. The two connector-types are not interchangeable and mating one with the other will damage both the cable and the module connectors.

Warning! The specification of optical connector is critical to the performance of the complete fibre optic link. System performance can only be guaranteed with fibre optic cables and connectors supplied by PPM. When FC/APC connectors are specified they must be “narrow key width”

3.2.2 Connecting and disconnecting

Before connecting optical fibres to the module or to each other, ensure that the mating connectors are clean (see below).

3.2.3 Cleaning optical connectors, cleaning before every use

Optical connectors **MUST** be cleaned before use, even where they have been protected with dust caps. **Most performance issues are due to dirty fibres.**

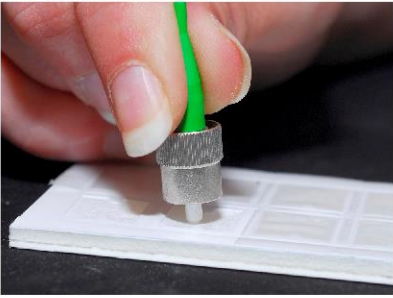

- Peel the plastic cover from an unused “N” cleaning pad.
- Hold the connector between your thumb and forefinger

Clean the connector using firm pressure by swiping in a pendulum motion through each segment of the “N” shape, following the diagram

- Do not swipe over the same space twice.

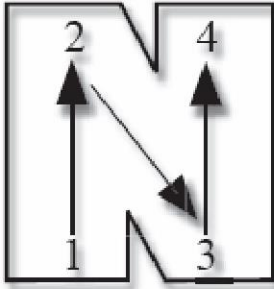

For more details please read the cleaning instruction which accompanies the connector cleaning kit.

Cleaning optical connectors, high levels of contamination

If there are performance issues that are not resolved by basic cleaning in section 3.2.3, then the following procedure should be used. If the level of contamination is high it will be necessary to repeat this procedure.

Cleaning items required:

- Lint free fibre cleaning tissues and/or cleaning sticks (normal cosmetic tissues produce dust and are not acceptable).
- Reagent grade Isopropyl alcohol (IPA).
- Air duster or filtered compressed air line.

Cable Connector Cleaning:

- Dampen a patch of cleaning tissue with IPA and clean all surfaces of the plug ferrule.
- Using a dry cleaning tissue, dry the ferrule and clean the end face.
- Using the air duster, blow away any residue from the end of the connector.

Module Female Receptacle Cleaning (only recommended if problems are being experienced):

- Either use an optical cleaning stick or twist a cleaning tissue to form a stiff probe, and then moisten with IPA. Gently push the probe into the receptacle and twist around several times to dislodge any dirt.
- Repeat the above process with a dry tissue.
- Using the air duster, blow away any residue from the receptacle.

Important Notes:

- IPA is flammable. Follow appropriate precautions / local guidelines when handling and storing.
- IPA can be harmful if spilt on skin. Use appropriate protection when handling.
- It should only be necessary to clean the female receptacles on the modules if problems are being experienced.

Never inspect an optical fibre or connector with the naked eye or an instrument unless you are convinced that there is no optical radiation being emitted by the fibre. Remove all power sources to all modules, and completely disconnect the optical fibres.

3.2.3.1 FC/APC

All PPM FC connectorised modules use FC/APC (narrow key). Clean the plug before inserting see section 3.2.3.

To connect FC/APC optical connectors:

- Remove the dustcaps and align the white ceramic centre ferrule on the cable connector with the mating receptacle.
- There is a key (lug) on the side of the ferrule, which must match the keyway (gap) in the receptacle shroud.
- When they are aligned, gently push the plug home.
- Tighten the collet nut onto the threaded receptacle to finger tightness.

To disconnect:

- Using fingers fully unscrew the knurled collet nut, gently withdraw the connector.
- Replace the dustcaps on both the receptacle and the cable plug.

Warning! It is possible to tighten the knurled collet without aligning the lug and gap. This will result in poor light transmission. Check that the lug and gap are aligned before tightening the knurled collet

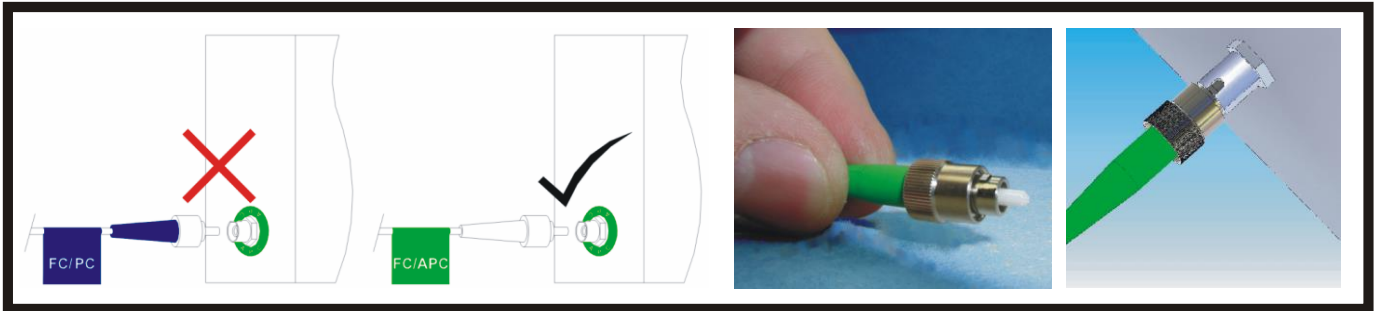

only connect FC/APC cable to FC/APC modules Locate connector key Align key and keyway

3.2.3.2 SC/APC

All PPM SC connectorised modules use SC/APC. Clean the plug before inserting, see section 3.2.3.

To connect SC/APC optical connectors:

- Remove the plug protective cover.
- Align the connector keyway slot in the adaptor to the key of the plug.
- Gently push the plug into the adaptor until a click is heard and the connector locks.

To disconnect, grip the body of the plug and gently pull the plug from the adaptor, before replacing the protective cover.

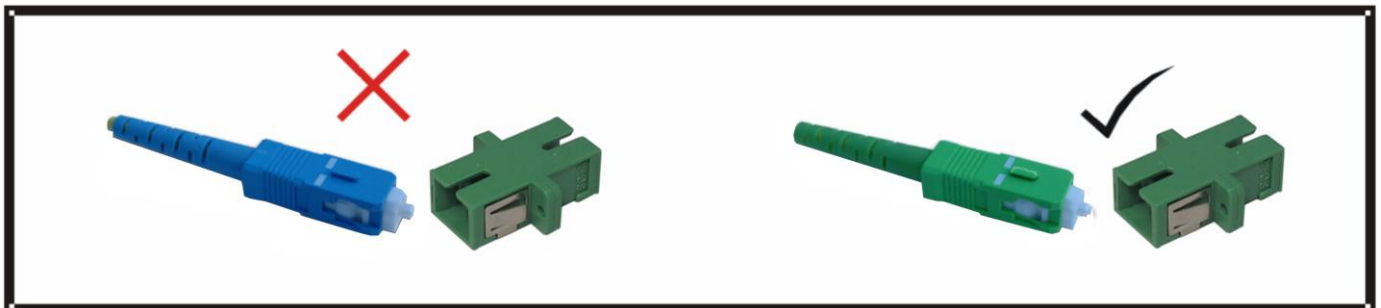

only connect SC/APC cable to SC/APC.

3.2.4 Minimum Bend Radius

Because the optical fibre is made of glass, it is important not to subject it to excessive stress. For this reason, each type of cable has a minimum bend radius (MBR) specification, beyond which the cable cannot be bent without permanent damage occurring.

Minimum Bend Radius of Fibre Optic Cable fitted to OEM modules is 50mm

MBR specifications for PPM fibre are given in the *ViaLite Classic* and **ViaLiteHD** System Handbook Lxx-HB and Hxx-HB.

3.3 Front panel

3.3.1 Front Panel Indicators, plug in modules

Each plug-in module has three front panel LEDs for indication of the state of the module. The following table shows the operation of the front panel LEDs which are dependent on module type.

	Colour	SNMP and Web controller
LED1	GREEN	Normal
	RED	Alarm
	No light	No power
LED2	GREEN	Rear RJ45 port link established
	No light	Rear RJ45 port unconnected
LED3	GREEN	Rear Fibre port link established
	No light	Rear Fibre port unconnected

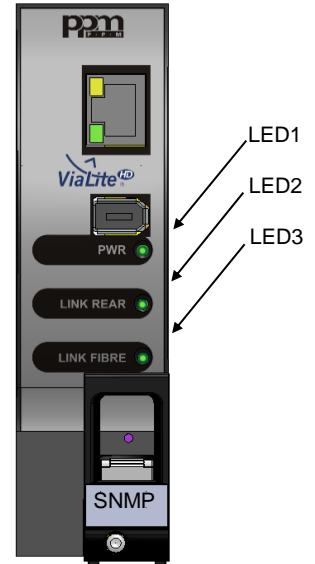

3.3.2 RJ45 Indicators, plug in modules

Each plug-in module has one front and two rear RJ45 connectors. Each has built in LED indicators to show the status of that connection. All RJ45 (and optical) Ethernet port connections are connected to an internal Ethernet switch.

	Colour	SNMP and Web controller
Link LED	AMBER or FLASHING	Link sending/receiving data
	No light	No data
Activity LED	GREEN	Link established
	No light	Unconnected

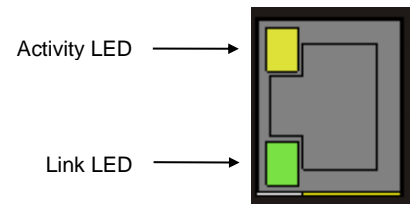

3.3.3 Front panel craft port and reset switch

Each SNMP and Web controller module is fitted with a craft port, this is used for low level set up and configuration. The craft port uses a Firewire, 6 circuit connector (IEE1394). The module is supplied with a Firewire to 9 way D type cable that can be used for configuration (PPM part number 73706). This can be ordered separately, if spares or replacements are required.

NOTE: The connector does not use the Firewire protocol, and will not work if a normal Firewire cable is inserted.

The hard reset switch is accessible via a small hole behind the handle. Under all normal operating circumstances it should not be required. Actuating the hard reset will cause the module to reboot.

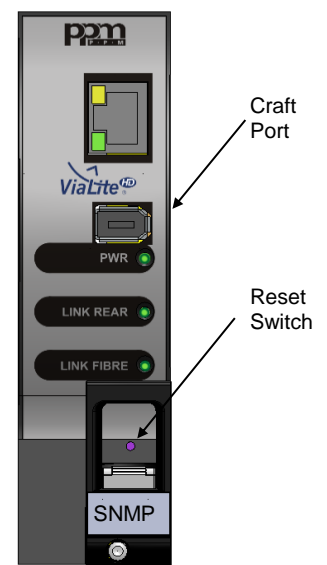

3.4 Rear panel

The rear panel provides interconnections for the chassis connector and the rear mounted RJ45 and optional fibre connectors.

The optional fibre connectors may be SC/APC (illustrated) or FC/APC. All RJ45 (and optical) Ethernet port connections are connected to an internal Ethernet switch.

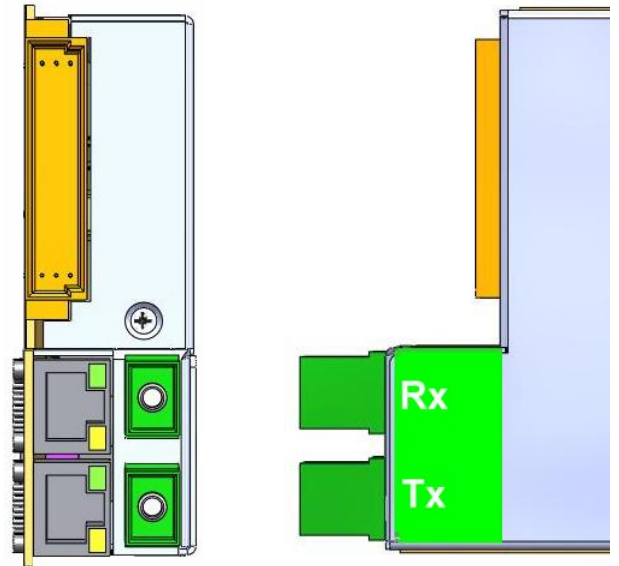

3.4.1 **Rear panel, connecting two SNMP and web controller via the fibre ports**

When connecting the fibre ports of an SNMP and web controller either to another SNMP and web controller (or to a 100 BaseF fibre transceiver). It is necessary to connect the ports correctly as they will not auto negotiate.

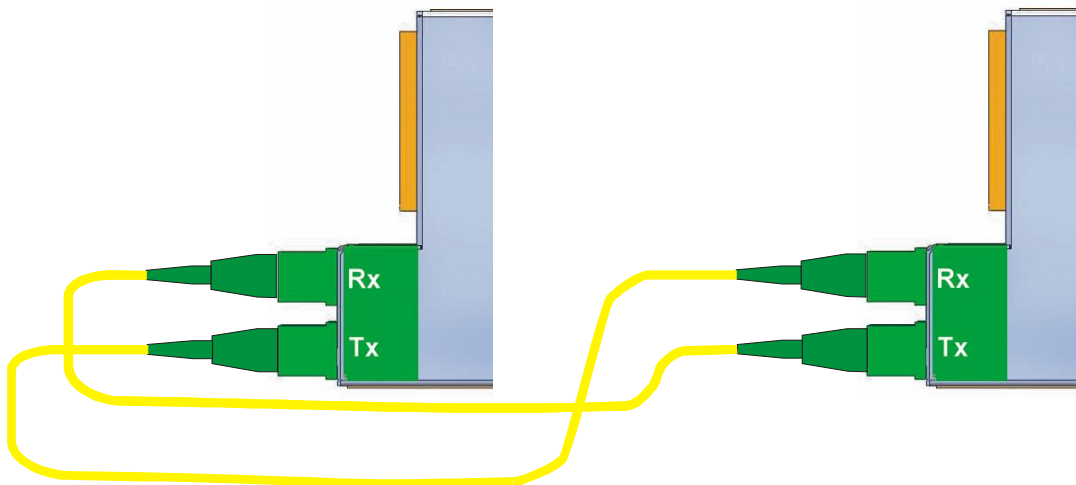

4 Setting up the SNMP and Web controller module

Your SNMP and web module is delivered fully configured, see section 2.1. Below are details of how to change from these default configurations.

4.1 Connecting the Module

Connect the module to the power source and Ethernet cables. Optionally you may also connect the module to fibre optic cables as described in section 3.3.3 and connect the dry contact relay (via chassis connector). All signals must remain within acceptable limits; see technical specifications in section 12.

4.2 Setting the IP address and serial interface

The module needs to be set up before connecting to the network. A computer with serial port and terminal program is needed. Screenshots in this manual relate to PuTTY, but any other terminal can be used.

1. Connect the module to the serial port using programming cable.
2. Open PuTTY.
3. Choose Serial connection type, and select the serial port **VialiteHD** chassis is connected to.

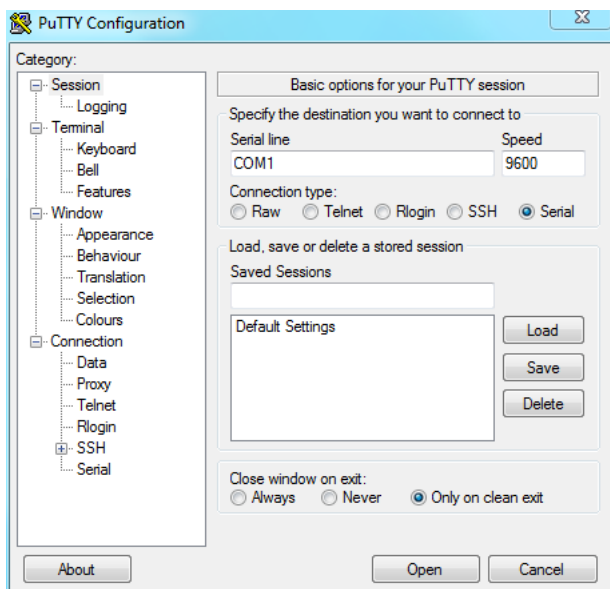

4. Click "Serial" at the bottom of the tree on the left, and set the serial port properties to 9600 bps, 8 data bits, 1 stop bit, no parity, no flow control.

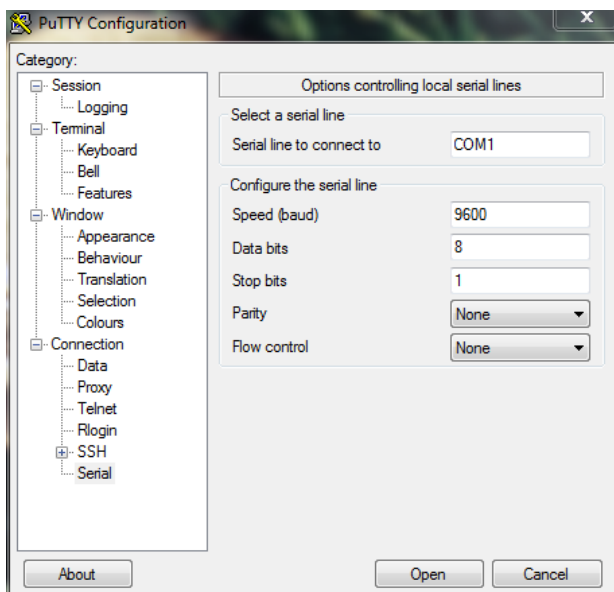

- Click Open to run the connection and power up the **ViaLiteHD** chassis. The screen should look like in the picture below.

Note: If you wish to access the configuration mode you must **hit any key within 5 seconds** of boot up.

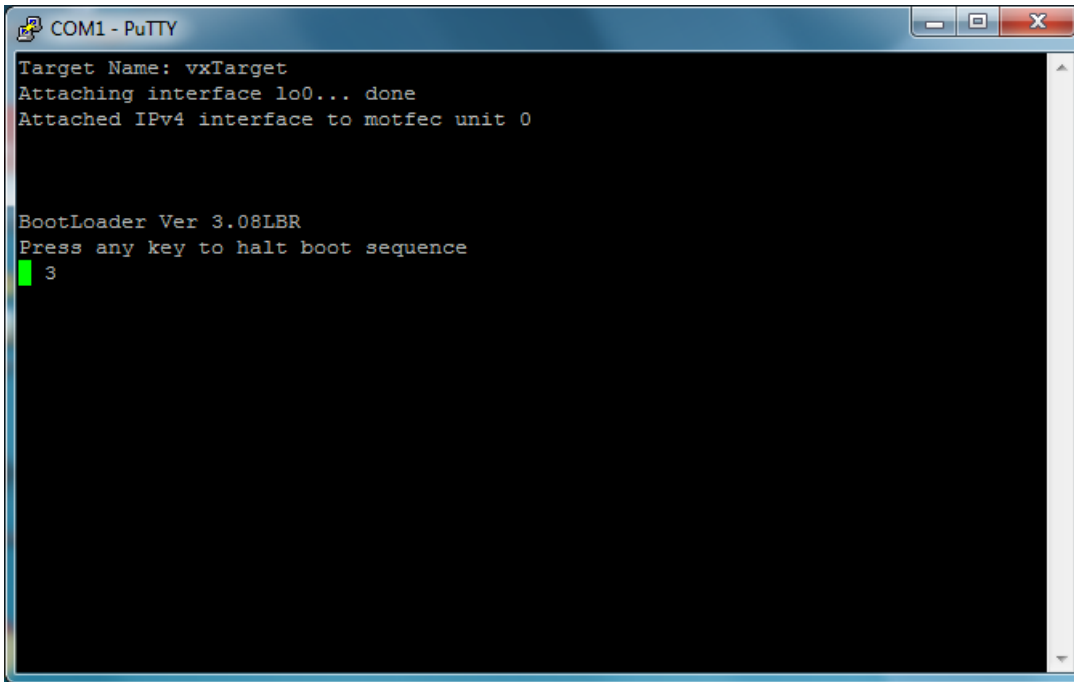

```
COM1 - PuTTY
Target Name: vxTarget
Attaching interface lo0... done
Attached IPv4 interface to motfec unit 0

BootLoader Ver 3.08LBR
Press any key to halt boot sequence
3
```

- If you do not press any key software will operate normally (see screenshot below). You will no longer be able to access the configuration mode; if access is required, a module reset is necessary.

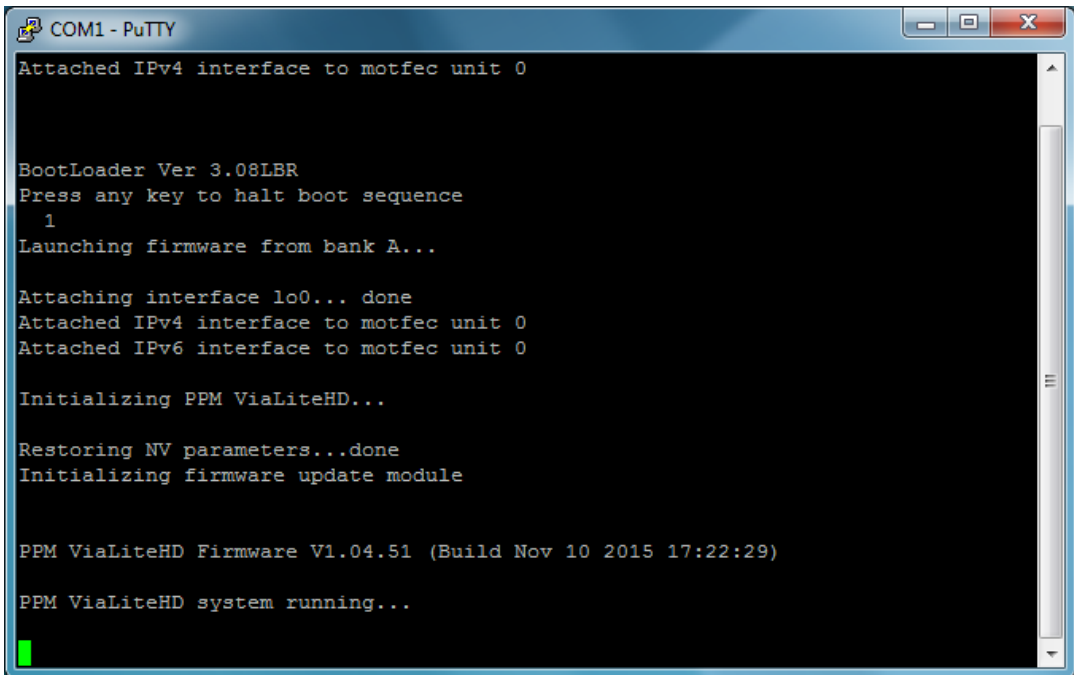

```
COM1 - PuTTY
Attached IPv4 interface to motfec unit 0

BootLoader Ver 3.08LBR
Press any key to halt boot sequence
1
Launching firmware from bank A...

Attaching interface lo0... done
Attached IPv4 interface to motfec unit 0
Attached IPv6 interface to motfec unit 0

Initializing PPM ViaLiteHD...

Restoring NV parameters...done
Initializing firmware update module

PPM ViaLiteHD Firmware V1.04.51 (Build Nov 10 2015 17:22:29)
PPM ViaLiteHD system running...
```

- If a key has been pressed, configuration mode is now active. To enter, type in the serial password. Default passwords are shown in section 2.1, but it should be changed at this stage. If the correct password has been entered, the main menu appears on the screen. It consists of four options.

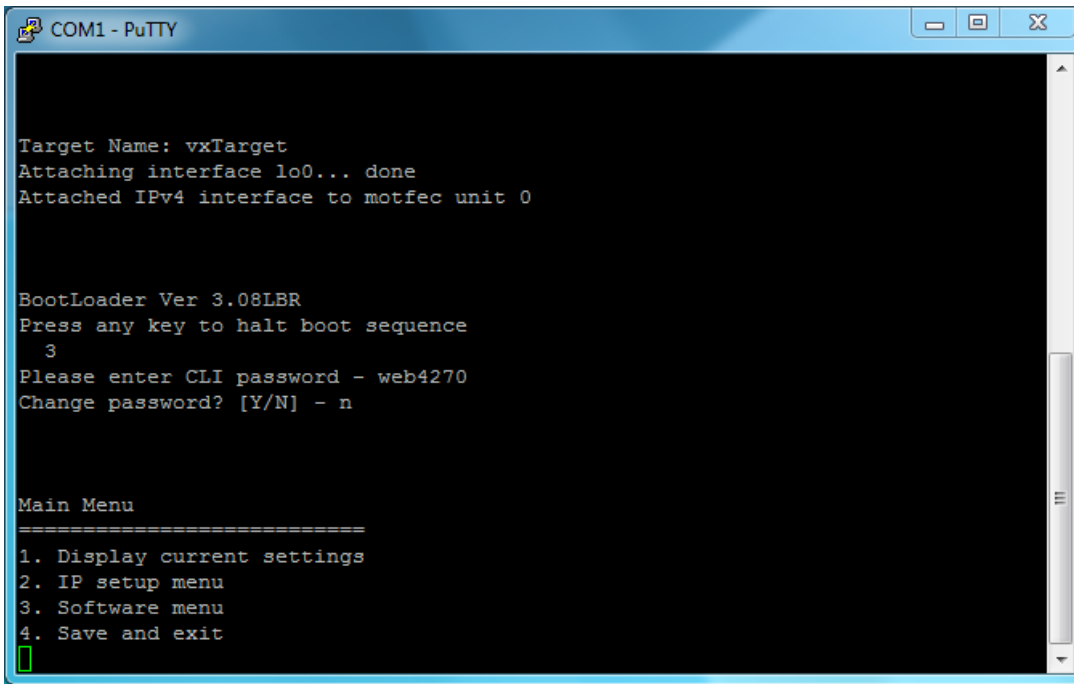

```

COM1 - PuTTY

Target Name: vxTarget
Attaching interface lo0... done
Attached IPv4 interface to motfec unit 0

BootLoader Ver 3.08LBR
Press any key to halt boot sequence
3
Please enter CLI password - web4270
Change password? [Y/N] - n

Main Menu
=====
1. Display current settings
2. IP setup menu
3. Software menu
4. Save and exit

```

8. Display current settings
Option displays current IP and FTP settings

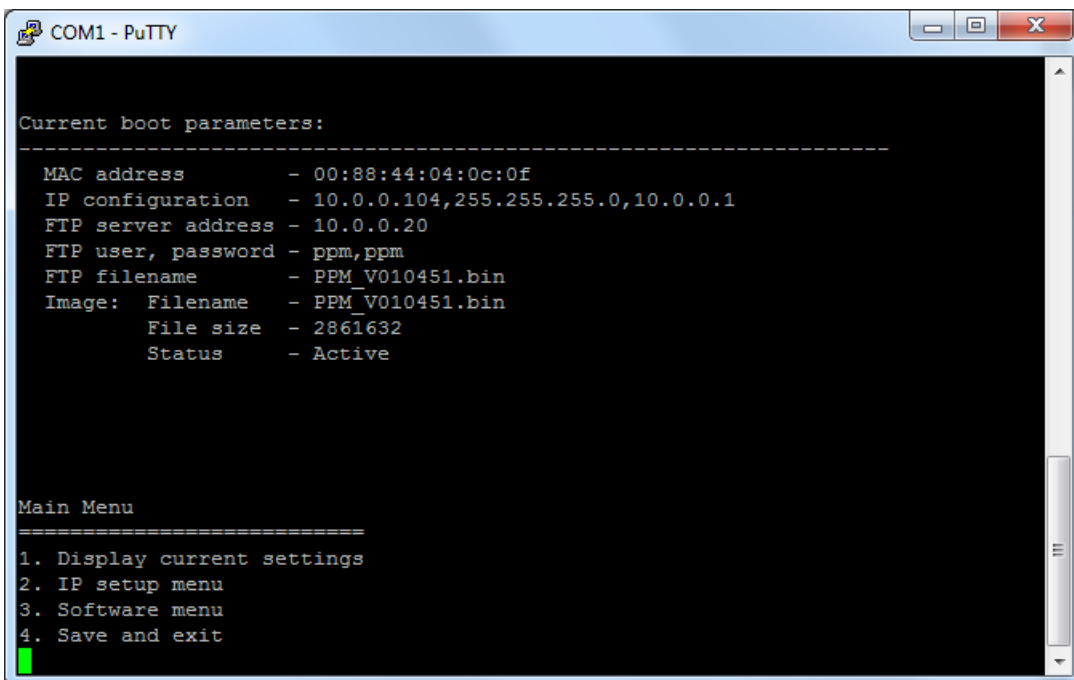

```

COM1 - PuTTY

Current boot parameters:
-----
MAC address      - 00:88:44:04:0c:0f
IP configuration  - 10.0.0.104,255.255.255.0,10.0.0.1
FTP server address - 10.0.0.20
FTP user, password - ppm,ppm
FTP filename     - PPM_V010451.bin
Image:  Filename - PPM_V010451.bin
      File size  - 2861632
      Status    - Active

Main Menu
=====
1. Display current settings
2. IP setup menu
3. Software menu
4. Save and exit

```

9. IP setup menu
IP address of the unit, netmask and default gateway can be set. Currently set values are in the brackets. Shall the value remain unchanged, just press Enter.

```

COM1 - PuTTY
FTP server address - 10.0.0.20
FTP user, password - ppm,ppm
FTP filename      - PPM_V010451.bin
Image: Filename   - PPM_V010451.bin
      File size   - 2861632
      Status      - Active

Main Menu
=====
1. Display current settings
2. IP setup menu
3. Software menu
4. Save and exit
2
Please enter IP parameters
IP address [10.0.0.104] -
Netmask [255.255.255.0] -
Default gateway [10.0.0.1] -

Modify the above or continue? [M/C] - █

```

After setting-up the parameters press C if values are correct or M to repeat the menu and modify settings.

10. Software menu.

This menu allows the user to download new software and to set SNMP communities. By default “public” is community name for read only operations, “private” for read/write operations. If software upgrade is not required, keep FTP settings unchanged by pressing ‘Enter’ and choose 2 to select Run (otherwise the unit will boot in the serial configuration mode). The unit will reboot into operation mode.

```

COM1 - PuTTY
Please enter IP parameters
IP address [10.0.0.104] -
Netmask [255.255.255.0] -
Default gateway [10.0.0.1] -

Modify the above or continue? [M/C] - c

Main Menu
=====
1. Display current settings
2. IP setup menu
3. Software menu
4. Save and exit
3
Please enter new boot parameters
SNMP Get community [public] -
SNMP Set community [private] -
FTP server address [10.0.0.20] -
FTP user [ppm] -
FTP password [ppm] -
FTP filename [PPM_V010451.bin] -
Boot operation [1:Download, 2:Run] - 2 █

```

```

COM1 - PuTTY
Current boot parameters:
-----
MAC address      - 00:88:44:04:0c:0f
IP configuration - 10.0.0.104,255.255.255.0,10.0.0.1
FTP server address - 10.0.0.20
FTP user, password - ppm,ppm
FTP filename     - PPM_V010451.bin
Image:  Filename - PPM_V010451.bin
       File size  - 2861632
       Status    - Active

Storing updated bootrecord...done

Launching firmware from bank A...

Attaching interface lo0... done
Attached IPv4 interface to motfec unit 0
Attached IPv6 interface to motfec unit 0

Initializing PPM ViaLiteHD...

Restoring NV parameters...done
Initializing firmware update module

PPM ViaLiteHD Firmware V1.04.51 (Build Nov 10 2015 17:22:29)

PPM ViaLiteHD system running...

```

Note that software upgrade requires a network connection and cannot be done using the serial port. The serial port is used only to set correct parameters for initial operation. The file to download has to be loaded to computer running an FTP server, see section 8.1 for details on setting up an FTP server. Upgrade can be done from GUI level, which is in most cases the most convenient way.

Note that downloading of incorrect files can prevent the unit from running and will require a factory upgrade.

11. In order to upgrade the software, set the FTP server name, username and password, as well as the name of the software file. Then choose 1 to download the new software version. After the download has finished, go to the Software menu and choose 2 to run the software. If you wish to leave a value unchanged, press enter when prompted for the new value.

```

COM1 - PuTTY
MAC address      - 00:88:44:04:0c:0f
IP configuration - 10.0.0.104,255.255.255.0,10.0.0.1
FTP server address - 10.0.0.39
FTP user, password - ppm,ppm
FTP filename     - PPM_V010451.bin
Image:  Filename - PPM_V010451.bin
       File size  - 2861632
       Status    - Ready

Storing updated bootrecord...done
done
Starting ftp transfer...done
Erasing Flash...Loading.....done
.....done
Storing updated bootrecord...done

Main Menu
=====
1. Display current settings
2. IP setup menu
3. Software menu
4. Save and exit

```

12. Save and Exit
Use this option to save the changes done in the process

4.3 Configuring chassis slot positions

The SNMP and web controller is able to automatically recognise the type of module fitted in each slot. This allows it to use the correct type of graphic for the front panel representation and present an appropriate control interface. The only module that is not recognised by the SNMP and web controller is the redundancy load module; this will just show as a blank slot.

In the unlikely event that the modules fitted in your chassis post-date the software load on your SNMP card, it will present a default graphic and a control interface that contains the basic module information.

4.4 Setting SNMP protocol community names

SNMP community names are password equivalents for the SNMP protocol, and set the access level. There are two communities defined, one is "get community" which allows for read only operations; the "set community" allows both reading and writing to the unit. Following convention, the default get community name is "public" while the default set community name is "private". Community names can only be changed using the craft port. It is not possible to change them via any network protocol.

1. In order to change settings for SNMP communities, open the serial configuration menu (as previously described in section 4.2) and choose option 3, 'Software menu'.

Note: If you wish to access the configuration mode you must hit any key **within 5 seconds** of boot up.

2. Select option 2 to change the SNMP community names.
3. Current values are displayed in parenthesis. If they are to remain unchanged, press 'Enter' to confirm current value.
4. If the entered values require changing before saving (for example, a typo), press 'M' to enter them again. Otherwise, press 'C' to continue.
5. In the example below, the SNMP community names were changed (from "public" to "public_community" and from "private" to "private_community") while the other parameters remained unchanged.

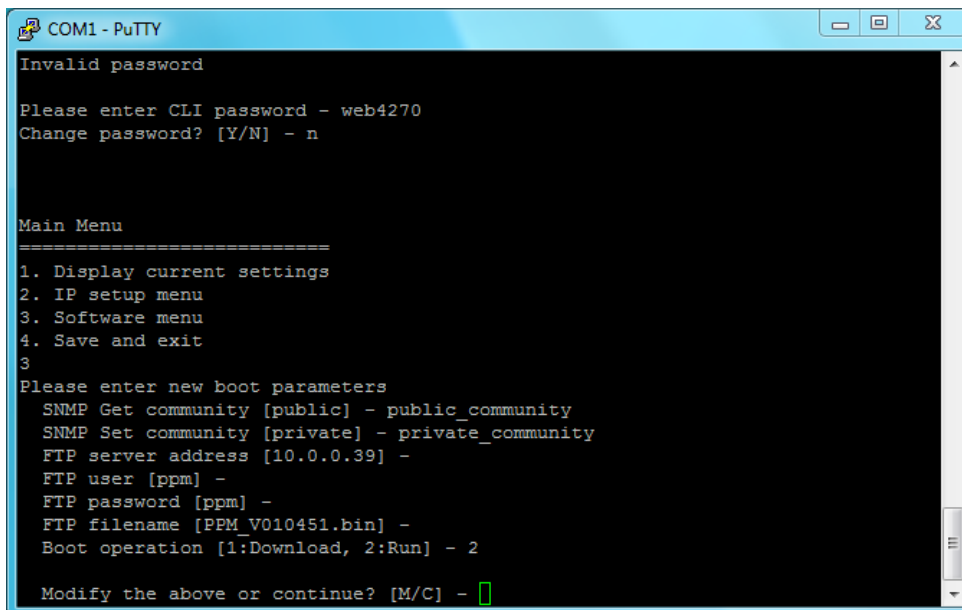

```

COM1 - PuTTY
Invalid password

Please enter CLI password - web4270
Change password? [Y/N] - n

Main Menu
=====
1. Display current settings
2. IP setup menu
3. Software menu
4. Save and exit
3
Please enter new boot parameters
SNMP Get community [public] - public_community
SNMP Set community [private] - private_community
FTP server address [10.0.0.39] -
FTP user [ppm] -
FTP password [ppm] -
FTP filename [PPM_V010451.bin] -
Boot operation [1:Download, 2:Run] - 2
Modify the above or continue? [M/C] - 

```

6. If the mode of operation is 'Run' after pressing 'C', the unit reboots and after a short period is ready for normal operation.

5 Connecting to the SNMP and web controller

Your SNMP and web module is delivered fully configured, see section 2.1. Below are details of how to change from these default configurations

5.1 Computer software environment

It is necessary to ensure that your connected computer is correctly configured.

Firstly ensure that your PC meets the minimum requirements, it must have:

1. Windows XP, service pack 2 or later.
2. Microsoft Internet Explorer 8.0 or later.
3. Java Plug-in 1.6.0 or later.

5.2 Computer IP configuration

Physically connect the Ethernet port of your computer either directly the SNMP and web controllers front or rear panel Ethernet ports; or to a network that this unit is connected to via a router or switch. Ensure that your PC has a valid IP address issued by the Dynamic Host Configuration Protocol (DHCP).

If your computer is connected directly to the SNMP controller you will need to configure its IP address manually.

Note: this requires local administration privileges; you may need to contact your network administrator if you do not already have permission to change these settings.

1. Right click the network indicator on the taskbar and select "Open Network and Sharing Centre".

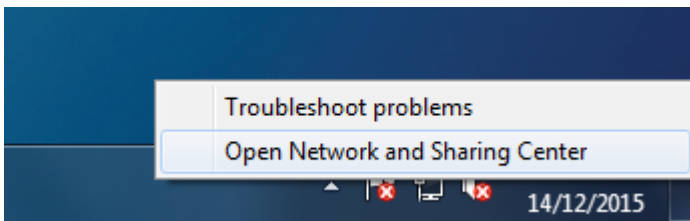

2. Click "Change adapter settings" in the top left corner.

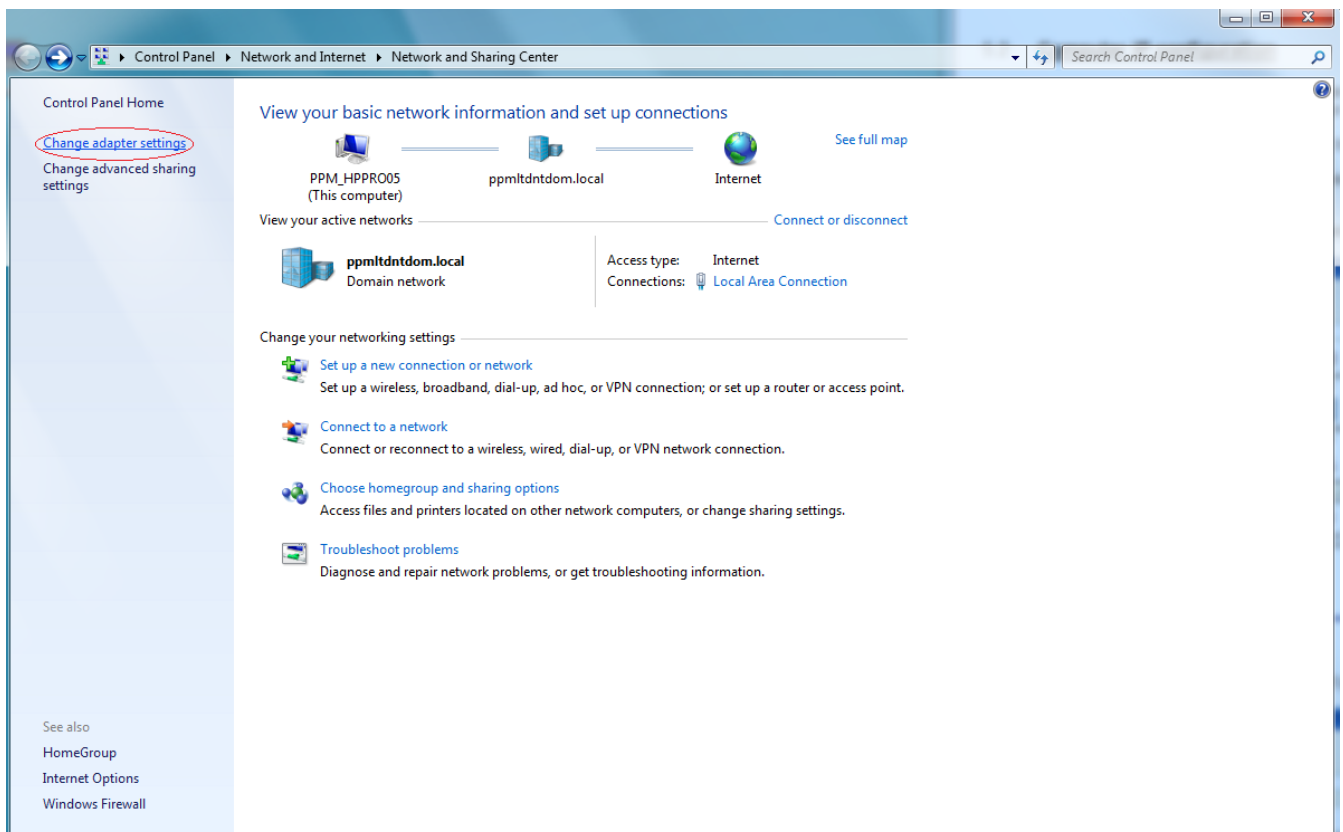

3. Right click the device connected to the Vialite SNMP module and click "Properties".

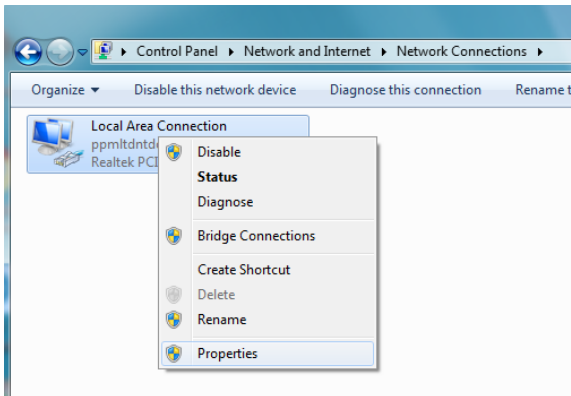

4. Left click "Internet Protocol Version 4 (TCP/IPv4)" (making sure not to clear the check box) and then left click Properties.

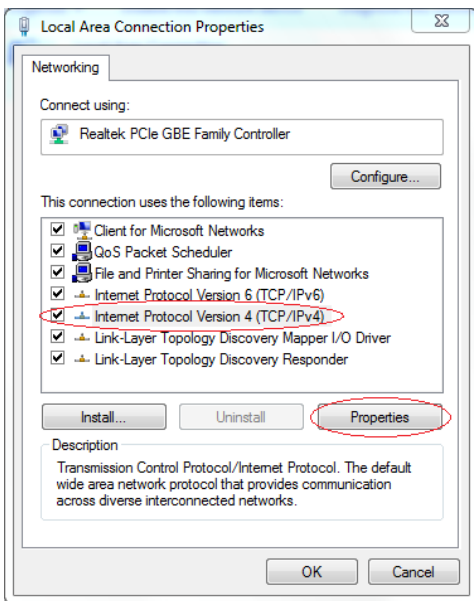

5. Select "Use the following IP address:" and then input the following settings.

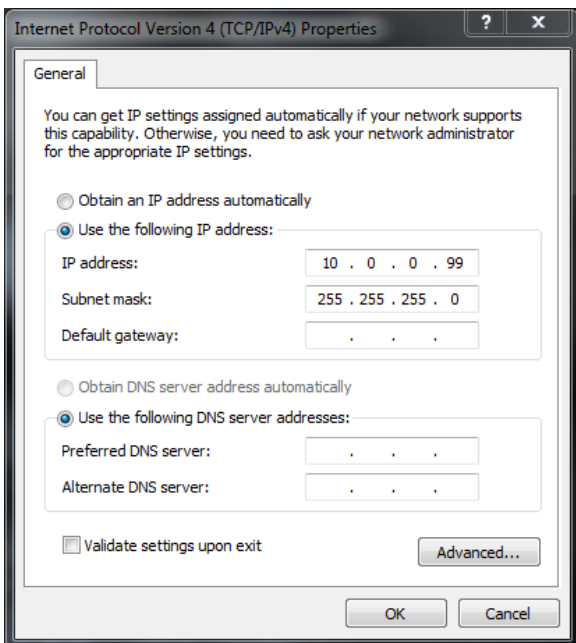

5.3 User access levels and passwords

There are three levels of user access allowed on the GUI, these are:

Access Level	username	Description
Guest	Guest	can read all parameters except advanced, cannot modify configuration or execute any commands
Admin	Admin	can read all parameters except advanced, can modify configurations and execute commands
Tech	Technician	can read and modify everything, all commands available

Each access level has a pre-set default password, these passwords are:

Access Level	username	Default password
Guest	Guest	guest
Admin	Admin	admin
Tech	Technician	tech

Usernames cannot be changed, but the passwords may, see the following section.

Note: The usernames and passwords for web access are case sensitive.

5.4 Setting user access passwords

By default the Telnet password is unset (not enabled), before you can use Telnet interface you must first set the "CLI password", see section 4.1. This is a security feature which prevents remote access to the chassis using the default password.

After setting the CLI password will be the same for both the Telnet and serial interfaces. You will then be able to use the CLI password for either serial interface console window or Telnet.

To set user access password you must log onto the module using telnet or a similar system. This guide uses PuTTY, but other clients can be used.

1. Open PuTTY, select the Telnet button, and input the IP address of your chassis into the IP address field.

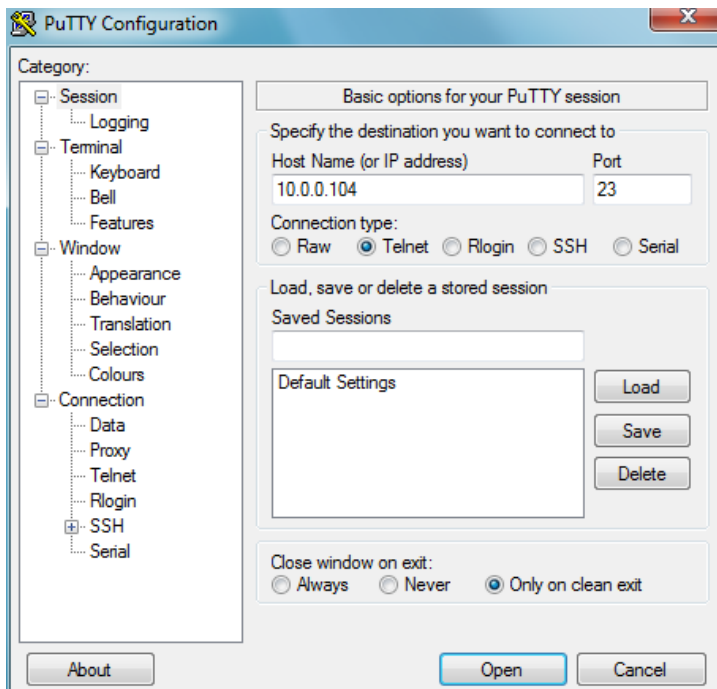

2. Ensure Local echo is set to Force on. This is in the “Terminal” section selected in the menu on the left.

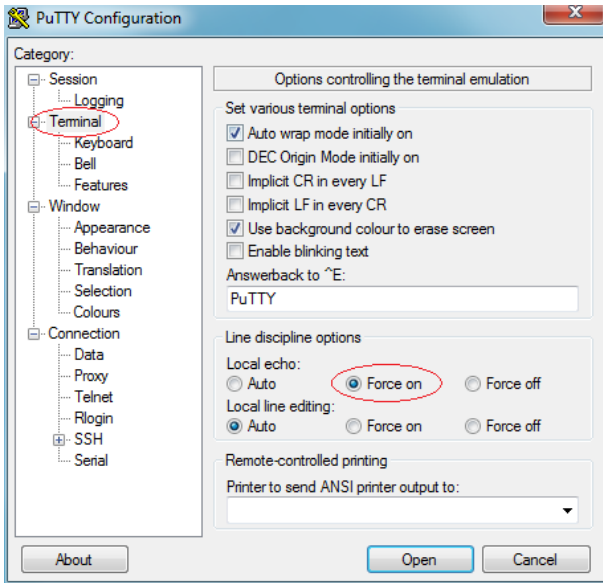

3. Open a telnet session by clicking the Open button.
4. You will be prompted for the telnet password this is the same as used or set in section 4.2, default password are shown in section 2.1, note this password is case sensitive. When the correct password is entered the unit will display a command prompt, “ViaLiteHD>”.

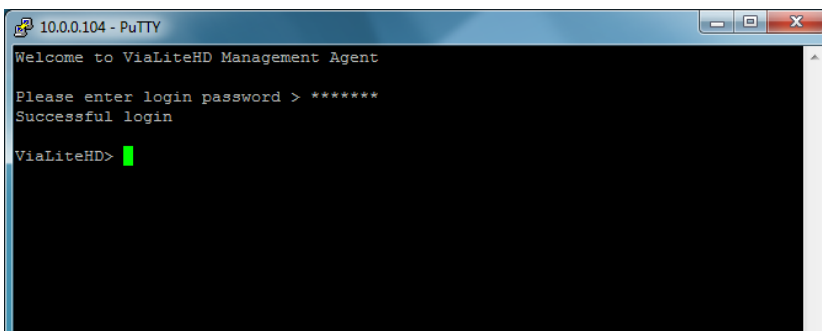

5. There are three user levels: Guest, Admin, and Technician. To view the current passwords, type “show http password”.
6. Now change the passwords as desired using the set http password command, as shown below. Note these passwords are case sensitive. You can confirm the passwords by again using the “show http password” command.

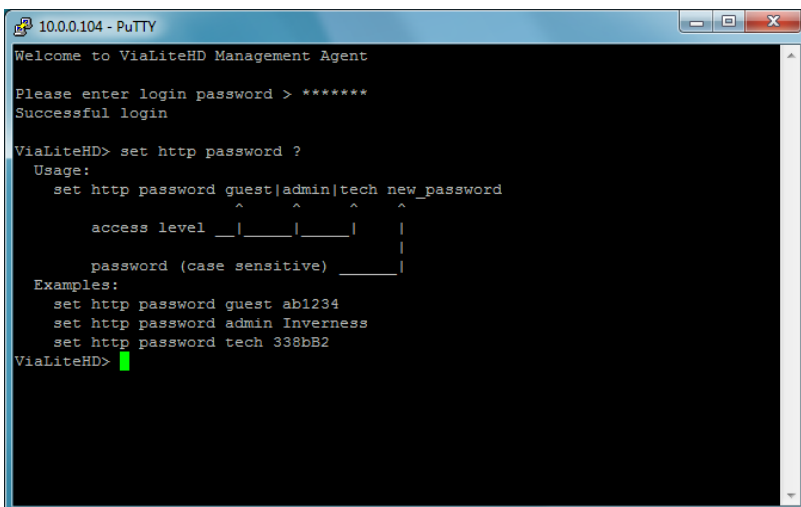

7. You should now log off by typing “logoff” and pressing any key when prompted. Failure to logoff and close the telnet session correctly may impact the card functionality. If this happens it may simply be rectified by a hard reset.

5.5 Other telnet commands

The Telnet interface may be used for a number of other actions, detailed below.

1. You may check all available commands by typing "?".
2. The following commands are available:
 - “**show version**” (no arguments are required) – Shows the current firmware version.
 - “**show ip**” (no arguments are required) – Shows the current IP settings.
 - “**show http password**” (no arguments are required) – shows passwords for HTTP interface.
 - “**set http password**” – sets passwords for HTTP interface.
Format required
“set http password <access level> <new password>”.
 - “**reboot**” (no arguments are required) – reboots device.
 - “**log off**” (no arguments are required) – logs out from telnet session.
3. You can check the format of a specific command by typing the command followed by "?".

6 Using the web control interface

6.1 Box control conventions

All buttons and icons can be activated by a single left click.

Some boxes have arrow icons in the top left of the box, these allow the boxes to be maximised or minimised.

Many boxes have a hover function. If you hover the point over a module it will display it key information, some boxes with settable parameters will also display their valid range if you hover over them.

If information is entered as text, numbers or drop down boxes you must hit the window apply button to send this information to the controller.

Changes should be applied individually, once implemented the next change should be made. This prevents the possibility of changes overwriting each other or control words being incorrect.

6.2 Opening the web the graphical user interface with a web browser

First open a web browser. The web browser must be java enabled and have Java Plug-in 1.6.0 or later loaded, if not you will be prompted to download this.

Type the IP address of the module into the browser address line, in this case "10.0.0.104".



After having typed in the module address you will be prompted for the password. Use the user name and password that you have chosen previously (see section 5.3 and 5.4).

Once the correct password has been input, the web interface will ask for the Set and Get communities. Use the values you have set using the serial interface, or the defaults if you have left them as such. If correct, the graphical interface will be displayed (See 6.3). If incorrect you will be prompted to re-enter your communities.

NOTE: SNMP communities are only fully supported in version 10.4.51 and above.

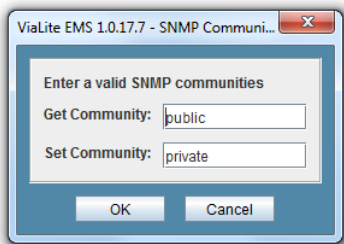

6.3 Graphical user interface, introduction screen

This is the first screen that the web page will open with; it displays a graphical overview of the chassis and modules, with basic information like status lights. Every model of chassis has its own custom graphical interface.

6.4 Top bar

IP address

Location – This is user definable text and can be entered on the system menu.

Name – This is user definable text and can be entered on the system menu.

Contact – Manufacturer or suppliers contact information, this is user definable text and can be entered on the system menu.

Log in name

Note: The IP address is the IP address as seen by the computer. This may be different to the IP address of the SNMP controller if you are accessing via an external network.

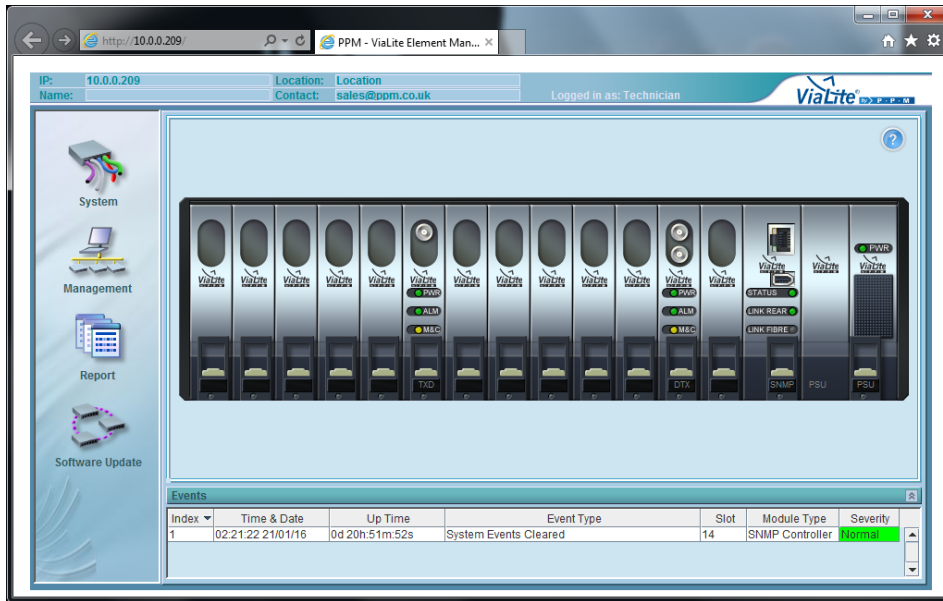

3U chassis

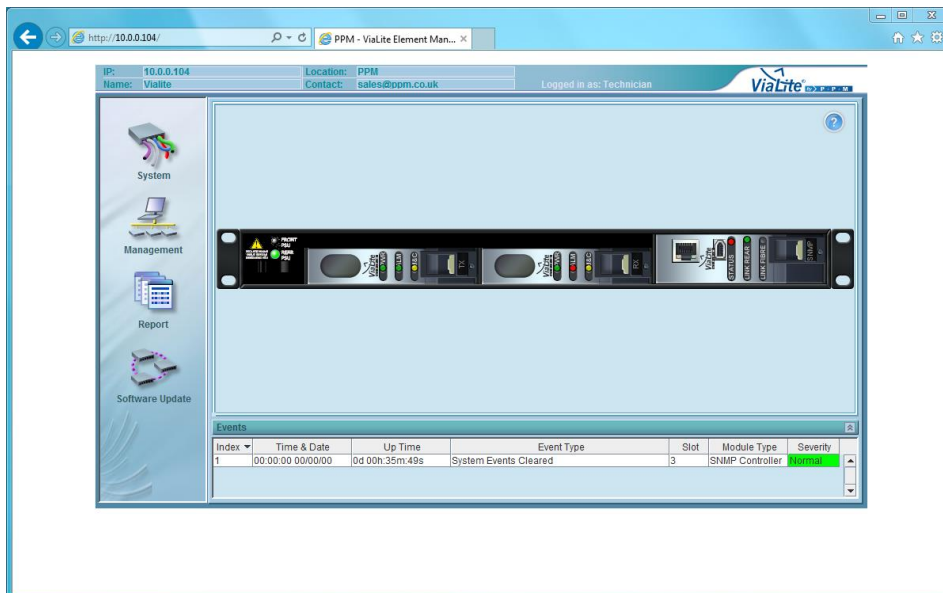

1U chassis

6.5 Left side bar

This bar contains views that may be used to set up and read parameters of the SNMP and Web controller.

System view – Allows viewing and setting of many controller, power supply and chassis parameters.

Management – Allows trap destination and MIB version to be set and read.

System report – This provides a summary report of the chassis and module information.

Software update – This allows the SNMP and web controller software to be updated via FTP.

6.5.1 Left side bar – System view

To open the system view, left click the system icon on the left side bar.

6.5.1.1 Left side bar – System view, properties

System view - Properties box

Description – This pre-set text described the module function.

Uptime – This reports the running time of the SNMP and web controller since the last reset.

Contact - This is user definable text and can be entered on this screen, it defaults to PPM contact details.

Name – This is user definable text (up to 30 characters) and can be entered on this screen, it defaults to “defaultName”.

Location – This is user definable text (up to 30 characters) and can be entered on this screen, it defaults to “defaultLocation”.

Note: Contact, name and location will be preserved during a system reset.

6.5.1.2 Left side bar – System view, properties, changing values

To change contact, name or location:

1. Left click the System icon on the left side bar; this opens the system view box.
2. The properties section will be visible by default.
3. Next click the box that you wish to update, enter the text. When the text has been input, click the apply button. You will be asked to confirm the action, click yes if you are sure. The change will come into effect immediately.

6.5.1.3 Left side bar – System view, inventory

System view - Inventory box

Product model – This gives the hardware model number.

SW version – This gives the version number of the GUI software loaded on the card.

Hardware revision – This gives the revision number of the SNMP and web controller hardware.

MAC address – This gives the MAC address of the SNMP and web controller hardware.

Serial number – This gives the serial number of the SNMP and web controller hardware.

6.5.1.4 Left side bar – System view, configuration

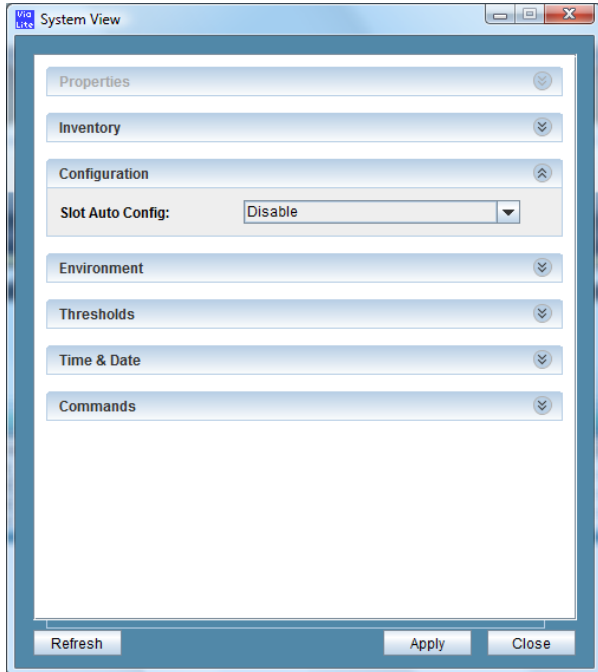

System view - Configuration box

Slot auto config – This is a user-settable option that allows the slot auto configuration option to be turned on and off. By default this feature is switched off. Full details of this special software feature are given in section 2.5.

6.5.1.5 Left side bar – System view, environment

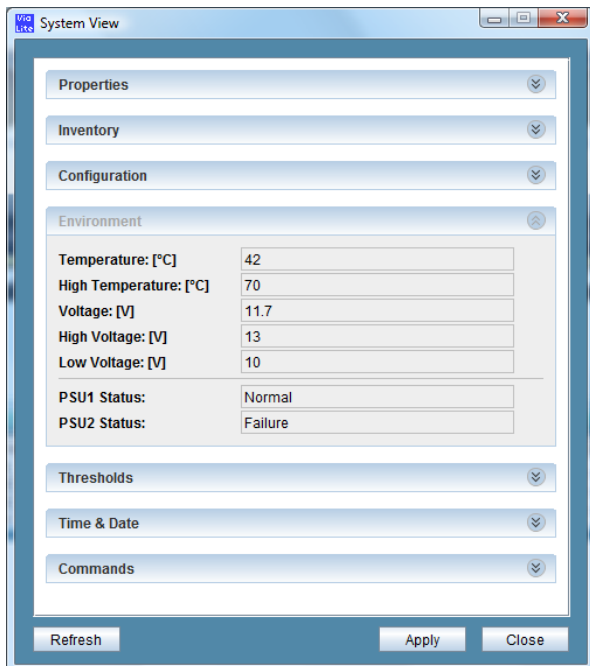

System view –Environment box

Temperature – This reports the temperature measured on the SNMP and web controller card.

Note: typically this is 15 - 20 degrees above the chassis ambient temperature.

High temperature – This reports the high temperature threshold, a reported temperature above the threshold will generate a “system temperature alarm”. The threshold can be set in the “Thresholds” section.

Voltage – This reports the chassis backplane voltage. Typical is around 12v.

High voltage - This reports the high voltage threshold, a reported voltage above the threshold will generate a “system voltage alarm”. The threshold can be set in the “Thresholds” section.

Low voltage - This reports the low voltage threshold, a reported voltage above the threshold will generate a “system voltage alarm”. The threshold can be set in the “Thresholds” section.

PSU1 status – This reports the status of the power supply in 3U chassis slot 15, its status can be Normal or Failure.

PSU2 status – This reports the status of the power supply in 3U chassis slot 16, its status can be Normal or Failure.

or

Front – Front PSU in 1U chassis.

Rear – Rear PSU in 1U chassis.

Note: As the PSU is unintelligent a status of Failure may be due to a real hardware failure or an unfitted PSU.

6.5.1.6 Left side bar – System view, thresholds

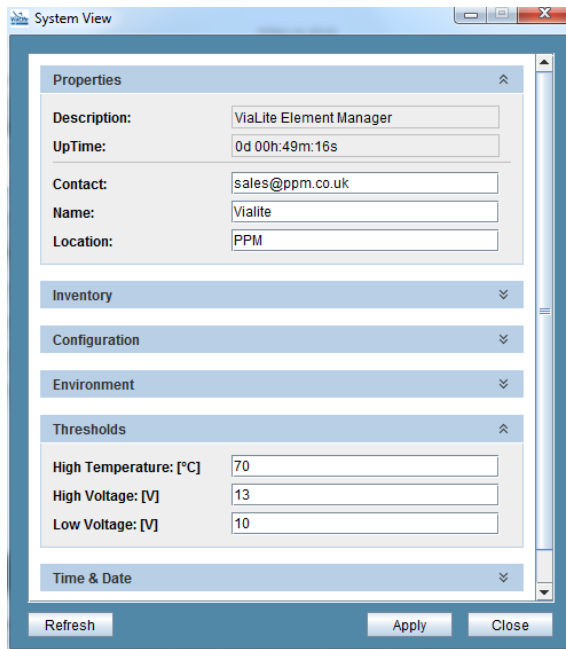

System view – Thresholds

High temperature – This is a user-settable threshold, it may be between 20 and 99, by Default it is set to 70 degrees centigrade.

High voltage – This is a user-settable threshold, it may be between 12 and 15, by Default it is set to 13 volts.

Low voltage – This is a user-settable threshold, it may be between 9 and 12, by Default it is set to 11 volts.

Note: Temperature and voltage thresholds will be preserved during a system reset.

6.5.1.7 Left side bar – System view, time and date

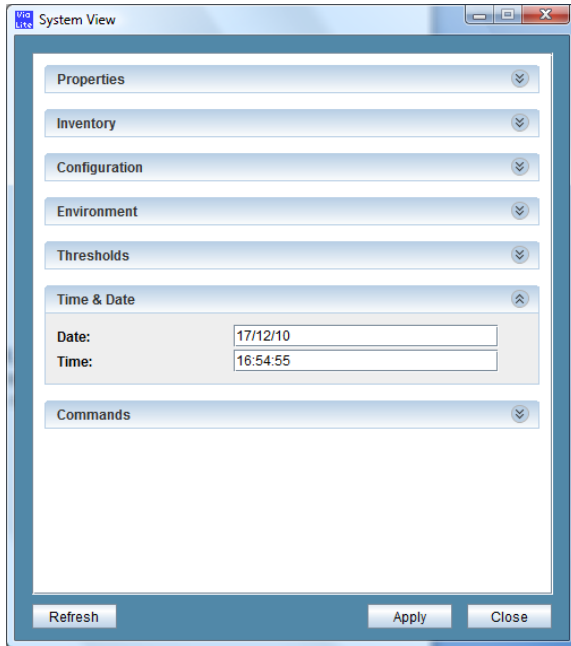

System view – Time and date

Date – This is user settable, it in the format DD/MM/YY.

Time - This is user settable, it in the format HH/MM/SS in a 24 hour format.

Note: The unit is equipped with a real time clock, which will preserve time and date in the event of a power outage or short storage period.

Note: Time and date will be preserved during a system reset.

6.5.1.8 Left side bar – System view, commands

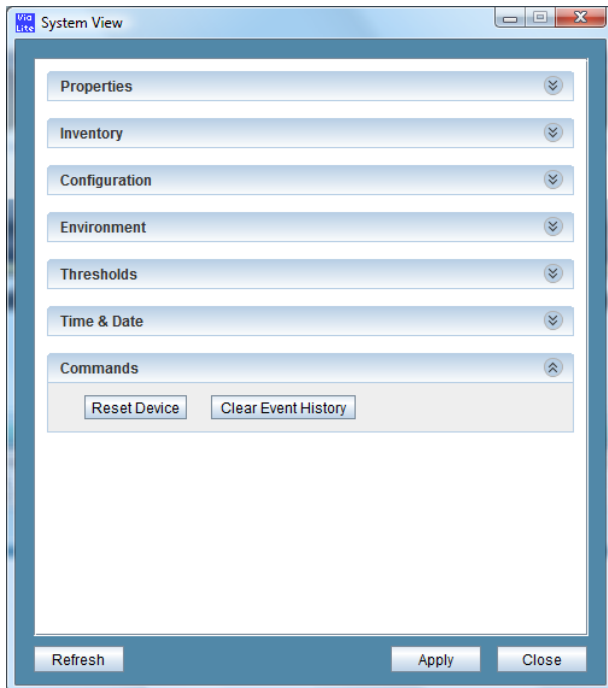

System view – Time and date

Reset device – This allows you to perform a soft reset on the SNMP and web controller card, before reset you will be prompted to confirm the action. A reset typically takes about 30 seconds. The reset does not clear the event history.

Clear event history - This allows you to clear the event history of the SNMP and web controller card, before clearing you will be prompted to confirm the action. The first event displayed after clearing the event log is "system events cleared".

Note: You cannot clear the event log if there are no other events.

6.5.2 Left side bar – Management

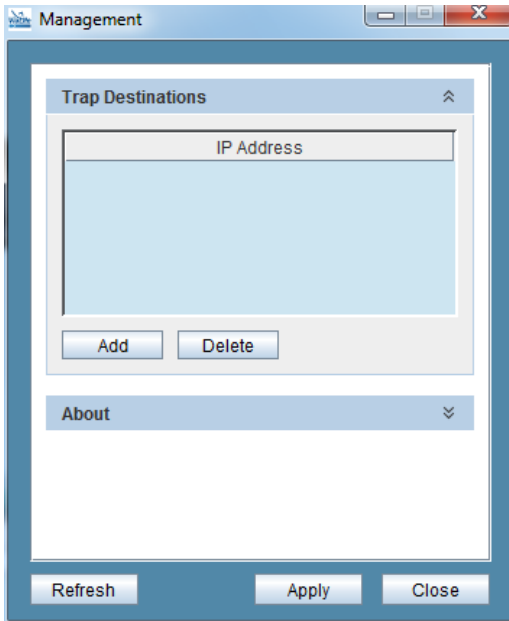

The management icon allows you to set up to five SNMP trap destinations. The traps are displayed in the IP address box.

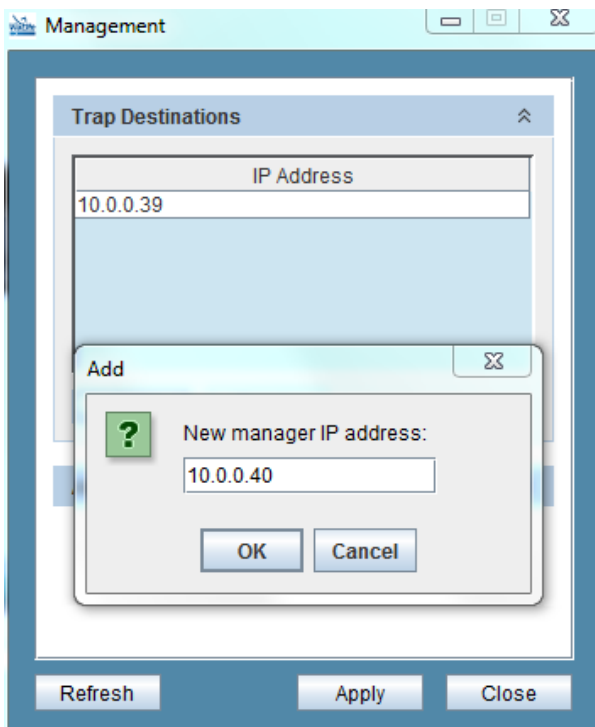

Traps can be added using the "Add" button, and deleted by selection them individually and pressing the "Delete" button.

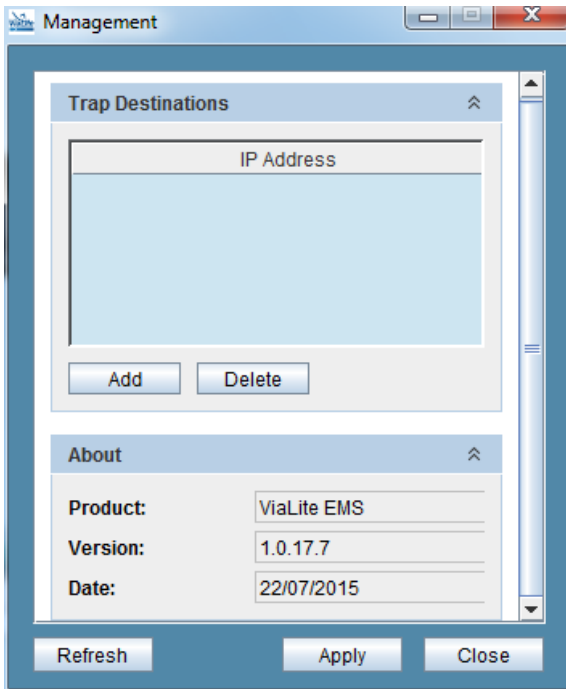

The about button maybe used to show the MIB software details

System view – Time and date

Product – This pre-set text described the product type

Version – This gives the version number of the software loaded on the card

Date – This gives the revision date of the software loaded on the card

6.5.3 Left side bar – System report

The system report is a tool that allows you to run either a status report on the modules that are corrected to the same chassis as the SNMP and web controller, or to report all the stored events. Both reports are exported as an HTML files.

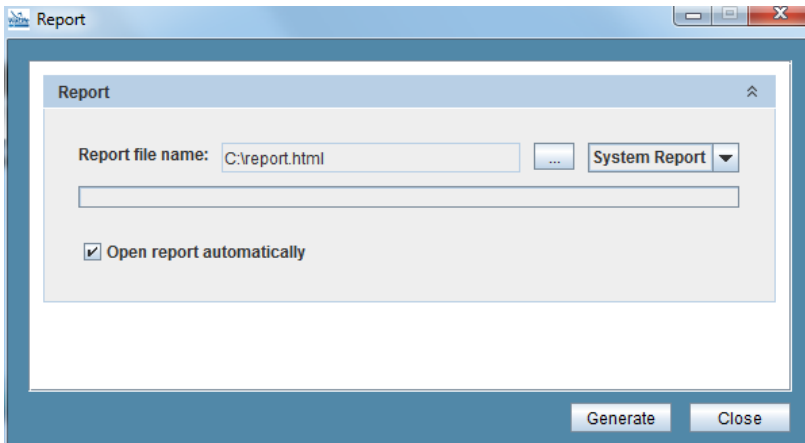

System report

Report file name – This displays the file name for the report file.

Pull down menu – This allows you to choose either a System Report or an Event Report.

Open report automatically - If this box is checked your web browser will automatically open the report after it is generated.

The System Report consists of a number of sections; these are detailed in the following sections.

6.5.3.1 Left side bar – System report, format, header and System Data

ViaLite EMS System Report - 14/12/15 11:05

System Data

IP: 10.0.0.104
Description: ViaLite Element Manager
Contact: sales@ppm.co.uk
Name: Vialite
Location: PPM

Product Model: ViaLiteHD HRC-1
SW Version: V1.04.51 Nov 10 2015 17:22:30
HW Revision: 1.0
MAC Address: 00:88:44:04:0C:0F
Serial Number: SN1240254

Slot Auto Configuration Disable

Temperature [°C]: 35
Voltage [V]: 11.6
Front Failure
Rear Normal
UpTime: 0d 00h:55m:46s

Date: 00/00/00
Time: 00:00:00

The header contains the time and date of the report, while the System Data field contains all the basic information about the chassis, SNMP, web controller, and power supplies.

6.5.3.2 Left side bar – System report, format, module table

This contains summary information on all the other modules in the chassis

Module Table

Slot	Card Type	Part Number	FW Part Number	FW Version	Serial Number
1	Transmitter	HRT-G1-8D-10-S1310	ViaLiteHD 82011	120	SN1240264
2	Receiver	HRR-G1-8D-60-	ViaLiteHD 82012	120	SN1240258

6.5.3.3 Left side bar – System report, format, module data

Module data – This contains detailed information on each module fitted in the chassis. Unpopulated slots are not reported.

Module Data

Slot1

General

Part Number: HRT-G1-8D-10-S1310
Type: Transmitter
FW Part Number: ViaLiteHD 82011
FW Version: 120
FW Date: 25 Apr 14
Serial Number: SN1240264
OEM Number: T1
Customer ID: None
Life Counter[H]: 48
Name:

Monitoring

Tx Supply Voltage[V]: 11.6
Tx Laser Bias[mA]: 43.5
Tx Laser Power[dBm]: 4.5
Tx RF Power[dBm]: -28.4
Tx RF Input[dBm]: -51.3
Tx RF Gain[dB]: -5
Tx Ext. Current[mA]: 2.9
Tx Ext. Voltage[V]: 5

6.5.3.4 Left side bar – System report, generating a system report

To generate the system report:

1. Left click the System Report icon on the left hand bar.
2. Click the “...” button on the right of the report file name box.
3. Navigate to the directory in which you wish to save the report.
4. Type a file name into the “file name” box.
5. File type cannot be changed; it will always generate an HTML file.
6. Then click save.
7. Check that **System Report** is selected in the pull down menu.
8. If you wish your web browser to automatically open the report after it is generated check the “open report automatically” box.
9. Now click the generate button.

6.5.3.5 Left side bar – System report, generating an Event report

To generate the event report:

1. Left click the System Report icon on the left hand bar
2. Click the “...” button on the right of the report file name box
3. Navigate to the directory in which you wish to save the report
4. Type a file name into the “file name” box
5. File type cannot be changed it will always generate an HTML file
6. Then click save
7. Check that **Event Report** is selected in the pull down menu, if not select it.
8. If you wish your web browser to automatically open the report after it is generated check the “open report automatically” box.
9. Now click the generate button.

6.5.4 Left side bar – Software update

This allows you to update the SNMP and web controller software via FTP.

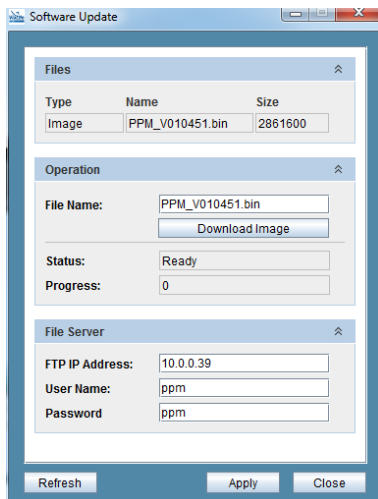

Software Update – Files

Type – This shows the type of file last uploaded.

Name – This is the file name last uploaded.

Size – This is the size of the file last uploaded in bytes.

– Operation

File name – This is a user text field in which the name of the file to be uploaded is stored.

Download image button – once all the download data fields have been correctly entered this is used to start the download.

Status – This shows the status of the download.

Progress – This shows the progress of the download.

File Server

FTP IP Address – This is a user field in which the name of the FTP server is entered.

User name – This is the user name to access your FTP server.

Password – This is the password associated user name to access your FTP server.

To perform a software update, see section 8.

6.6 Bottom event window

The **ViaLiteHD** SNMP and web controller has a window which displays system events. It provides a history of the last 128 events is stored in non-volatile memory on the SNMP and web controller. Each event is has an index number, this number is incremented with each new event.

The GUI is able to provide a visual indication of new events. When a new event occurs, the “event” text at the top of the event box will flash green and black. If you click this to acknowledge the event, the text will stop flashing until there is a new event.

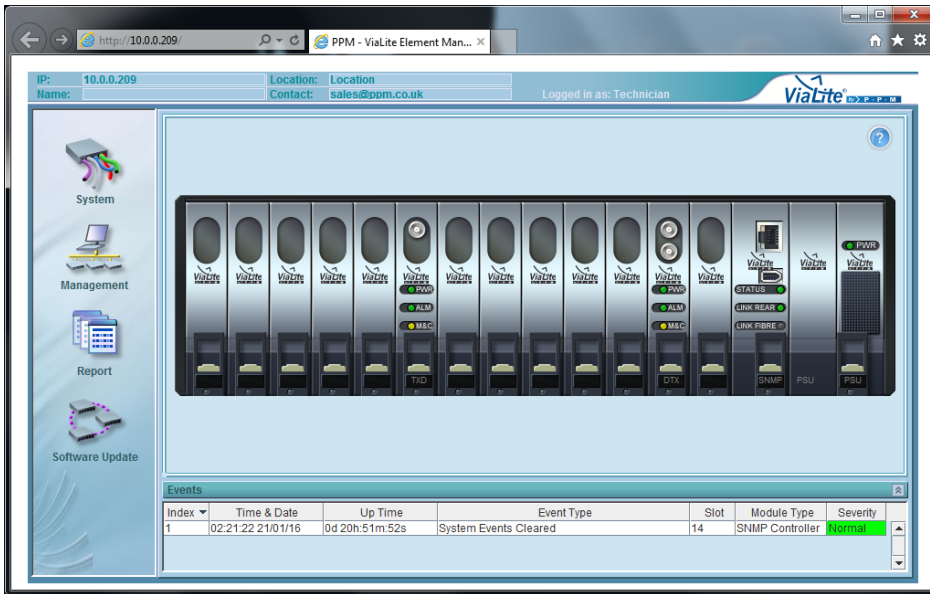

The last 128 events are stored, and each event generates an event index number starting at 1. The index number will increase each time there is a new event, it is not numerically limited. The index number is only reset (to 1) when the event log is cleared. Only the last 128 events are stored, earlier events are erased.

The event window can be maximised by clicking the arrows in the top right hand corner of the window. It can be minimised in the same fashion

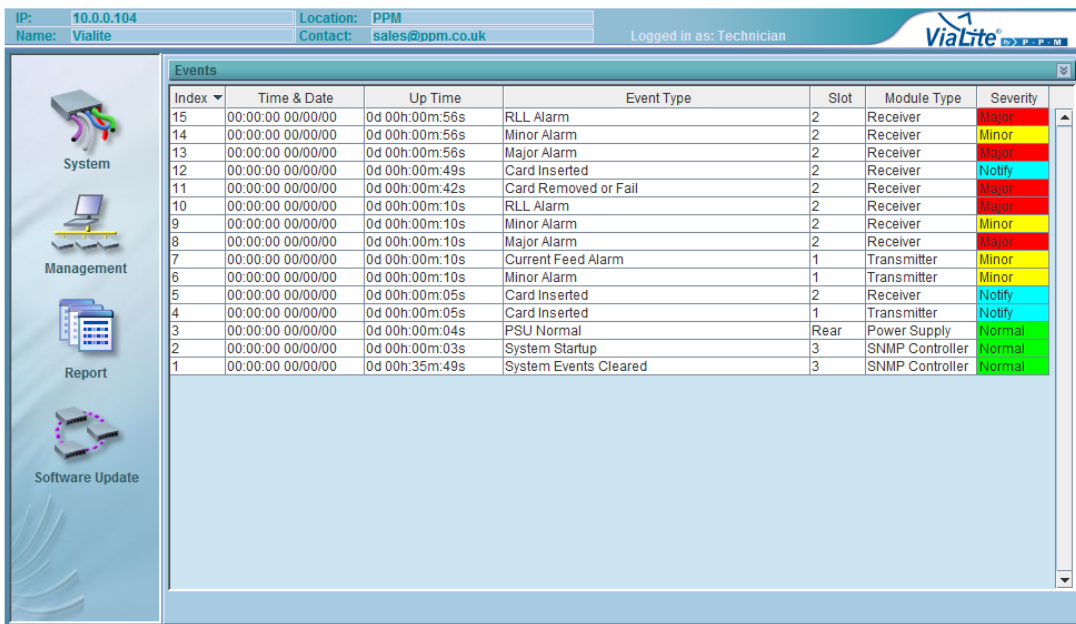

6.6.1 Bottom event window, event sorting

The events can be sorted by any of the event table columns, in both forward and reverse order.

- Index
- Time and date
- Uptime
- Event type
- Slot
- Module type
- Severity

Index	Time & Date	Up Time	Event Type	Slot	Module Type	Severity
4	00:00:00 00/00/00	0d 00h:00m:05s	Card Inserted	1	Transmitter	Notify
7	00:00:00 00/00/00	0d 00h:00m:10s	Current Feed Alarm	1	Transmitter	Minor
6	00:00:00 00/00/00	0d 00h:00m:10s	Minor Alarm	1	Transmitter	Minor
12	00:00:00 00/00/00	0d 00h:00m:49s	Card Inserted	2	Receiver	Notify
5	00:00:00 00/00/00	0d 00h:00m:05s	Card Inserted	2	Receiver	Notify
11	00:00:00 00/00/00	0d 00h:00m:42s	Card Removed or Fail	2	Receiver	Major
13	00:00:00 00/00/00	0d 00h:00m:56s	Major Alarm	2	Receiver	Major
8	00:00:00 00/00/00	0d 00h:00m:10s	Major Alarm	2	Receiver	Major
14	00:00:00 00/00/00	0d 00h:00m:56s	Minor Alarm	2	Receiver	Minor
9	00:00:00 00/00/00	0d 00h:00m:10s	Minor Alarm	2	Receiver	Minor
15	00:00:00 00/00/00	0d 00h:00m:56s	RLL Alarm	2	Receiver	Major
10	00:00:00 00/00/00	0d 00h:00m:10s	RLL Alarm	2	Receiver	Major
3	00:00:00 00/00/00	0d 00h:00m:04s	PSU Normal	Rear	Power Supply	Normal
1	00:00:00 00/00/00	0d 00h:35m:49s	System Events Cleared	3	SNMP Controller	Normal
2	00:00:00 00/00/00	0d 00h:00m:03s	System Startup	3	SNMP Controller	Normal

The default sort order is by index number. To change the sort order:

- Clicking the column heading you wish to use.
- Click it again to toggle between ascending and descending sorting.
- An up/down arrow is displayed on the heading by which the table is sorted, it indicates the sort direction.

6.6.2 Bottom event window, event severity

There are a number of levels of event severity these are all colour coded in the event window.

- Major alarm are coded **RED**
- Minor alarm are coded **YELLOW**
- Normal events are coded **GREEN**
- Notify events are coded **TURQUOISE**

The alarm are classified as follows

MAJOR alarm – These are typically events that may cause major disruption to operation, depend on deployment these may or may not be critically service effecting. Typical events to trigger this would be low light level at optical receivers (RLL Alarm), card removal or similar. Any major alarm will change the SNMP and web controller LED from green to red.

MINOR alarms – These are typically event that may degrade performance or warn of impending major alarms, they may affect the quality of service. Typical events would be system temperature alarm, RX AGC alarm, Voltage feed alarm or similar.

NORMAL event– These are events that would be expected to happen under normal operation. Typical type of events would be system start up and alarms being cleared.

NOTIFY event – These are the type of events that are useful to record as they represent a change in status. A typical type of event would be card insertion.

Following is a list of all the events types and their severity. The severity of the events is dependent on their event type and pre-set in the software.

Alarm description	Severity
AGC Alarm	MINOR
AGC Alarm Cleared	NORMAL
Bias Alarm	MAJOR
Bias Alarm Cleared	NORMAL
Card Inserted	NOTIFY
Card Removed	MAJOR
Current Feed Alarm	MINOR
Current Feed Alarm Cleared	NORMAL

Laser Alarm	MAJOR
Laser Alarm Cleared	NORMAL
Major Alarm	MAJOR
Major Alarm Cleared	NORMAL
Minor Alarm	MINOR
Minor Alarm Cleared	NORMAL
Overload Alarm Clear	NORMAL
Overload Alarm	MINOR
Power Alarm	MINOR
Power Alarm Cleared	NORMAL
PSU Alarm (power supply not present)	MINOR
PSU Alarm (power supply removed/fail)	MAJOR
PSU Normal	NORMAL
RF Gain Alarm	MINOR
RF Gain Alarm Cleared	NORMAL
RF Level Alarm	MINOR
RF Level Alarm Cleared	NORMAL
RLL Alarm	MAJOR
RLL Alarm Cleared	NORMAL
System Events Cleared	NORMAL
System Start-up	NORMAL
System Temperature Alarm	MINOR
System Temperature Alarm Cleared	NORMAL
System Voltage Alarm	MINOR
System Voltage Alarm Cleared	NORMAL
Temperature Alarm	MINOR
Temperature Alarm Cleared	NORMAL
Temperature Clear	NORMAL
Temperature Overload	MINOR
VCC Alarm	MINOR
VCC Alarm Cleared	NORMAL
Voltage Feed Alarm	MINOR*
Voltage Feed Alarm Cleared	NORMAL

*Voltage feed alarm user settable, minor by default.

6.7 Central chassis graphical interface window

The central window give a graphical representation of both the modules fitted in the chassis and there status



This window has the following features

- Each module should be represented in the correct slot.
- Each module should have a graphically correct front panel.
- Each of the modules LEDs should reflect the status of the actual module.
- Each module in slots 1-13 can be hovered over. This will display its slot number, part number and type.

For 3U, each module in slots 1-16 is clickable, with a single left click, this will bring up:

- Slot window for modules in slots 1-13.
- A System window in slot 14, with the Properties box maximised.
- A System window in slots 15 and 16, with the Environment window maximised.

For 1U, each module in slots 1-2 is clickable, with a single left click, this will bring up:

- Slot window for modules in slots 1+2.
- A System window in slot 3, with the Properties box maximised.

Note: The text on some module labels may be modified to improve readability.

Full detail of the operation of the modules and how they can be software controlled is given in the section 7 and its subsections.

7 Slot windows

7.1 Slot windows general information

This information is always available in every slots with a module fitted. The only exception is in a slot fitted with a redundancy load module; the redundancy load module has no processor and will show as blank. All modules have a name field that maybe used to store user defined text information of up to 32 characters. More details are given in section 2.15.

7.1.1 Slot windows general information, opening the slot window

To open any slot window:

1. Left click slot GUI image, this will open the slot window.

Note: If you hover over the window you will display the slot number, part number and type

2. The type of window that opens depends on the slot number
 - a. For Slots 1-13 a slot window will be opened
 - b. For Slot 14 a System window will open with the Properties box maximised (see 6.5.1.1)
 - c. For slots 15 and 16 a System window will open with the Environment window maximised (see 6.5.1.5)

7.2 Slot windows for TX type

The TX type module will open with the General box maximised

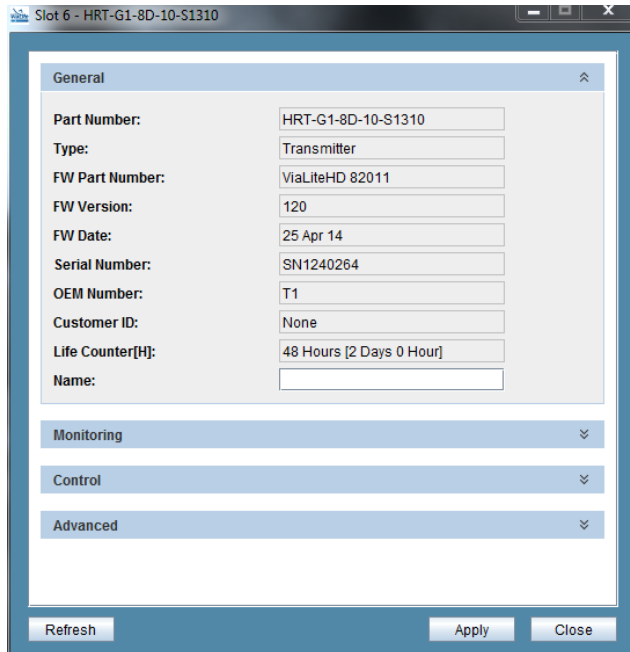

The screenshot shows a window titled "Slot 6 - HRT-G1-8D-10-S1310". The window contains a "General" tab with the following fields:

Part Number:	HRT-G1-8D-10-S1310
Type:	Transmitter
FW Part Number:	ViaLiteHD 82011
FW Version:	120
FW Date:	25 Apr 14
Serial Number:	SN1240264
OEM Number:	T1
Customer ID:	None
Life Counter[H]:	48 Hours [2 Days 0 Hour]
Name:	

Below the General tab are three expandable sections: "Monitoring", "Control", and "Advanced". At the bottom of the window are three buttons: "Refresh", "Apply", and "Close".

7.2.1 Slot window for TX type, monitoring

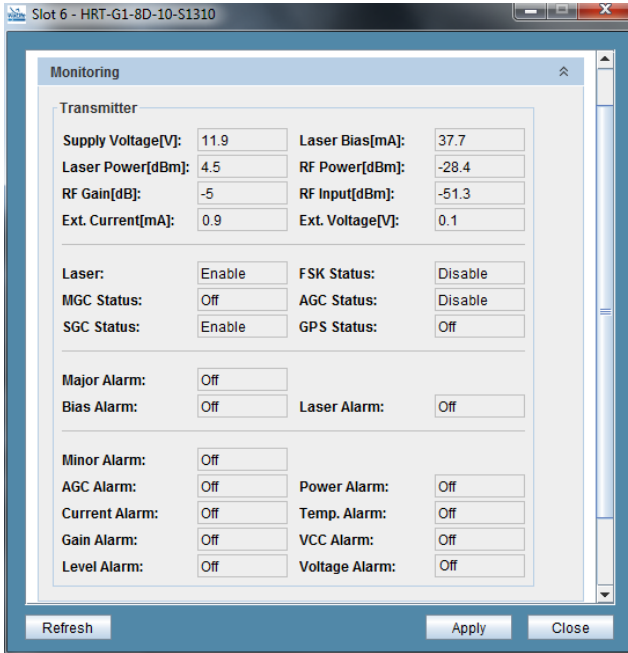

Slot window – TX type, monitoring

Supply voltage – This is the supply voltage measured at the input to the module, measured in volts. This should be close to 12V.

Laser power – This is the average optical power output of the laser, measured in dBm. For a standard Tx module this should be around 4.5dBm.

RF gain – This is the electro optic gain of the module measured in dB. This is set by the SGC value.

Ext. current – This is the average DC current flowing out of the RF input, measured in milliamps. Values depend upon connected equipment.

Laser bias – This is the current supplied to the laser diode, measured in milliamps. Typical is around 170mA.

RF power – This is the RF power measured at the input to the laser diode, measured in dBm.

RF Input – The RF input power, measured in dBm. The maximum value should be the P1dB of the module (see VialiteHD RF Link handbook).

Ext. voltage – This is the bias voltage measured at the RF input to the transmitter, measured in volts. Values depend on connected equipment.

Laser – This is the laser power control loop status, it can be enabled (on) or disabled (off).

MGC status – This is the manual gain control status, it can on or off.

SGC status – This is the software gain control status, it can on or off.

FSK status – This is the frequency shift key digital communications channel status, it can be enabled (on) or disabled (off).

AGC status – This is the automatic gain control status, it can be enabled (on) or disabled (off).

GPS status - This shows the status of the GPS mode, it can be on or off.

Major alarm – This is the major alarm status, it can be on (alarm active) or off.

Bias alarm – This is the laser current alarm status, it can be on or off.

Laser alarm – This is the laser control loop alarm status, it can be on or off.

Minor alarm – This is the minor alarm status, it can be on or off.

AGC alarm – This is the automatic gain control alarm status, it can be on or off.

Current alarm - This is the external feed current alarm status, it can be on or off.

Gain alarm – This is the RF gain alarm status, it can be on or off.

Level alarm – This is the RF power level alarm status, it can be on or off.

Power alarm – This is the laser output power alarm status, it can be on or off.

Temp alarm – This is the temperature alarm status, it can be on or off.

Vcc alarm – This is the (input) voltage alarm status, it can be on or off.

Voltage alarm – This is the external feed voltage alarm status, it can be on or off.

7.2.1.1 Slot window for TX type, monitoring, note on TX AGC

When set to operate in AGC mode the TX module can only operate in RF control mode.

When operating in RF mode, the TX module will use a slow control loop to set the power at the monitor to the AGC target level. The gain is continuously adjusted and is controlled in 0.5dB steps.

7.2.2 Slot window for TX type, control

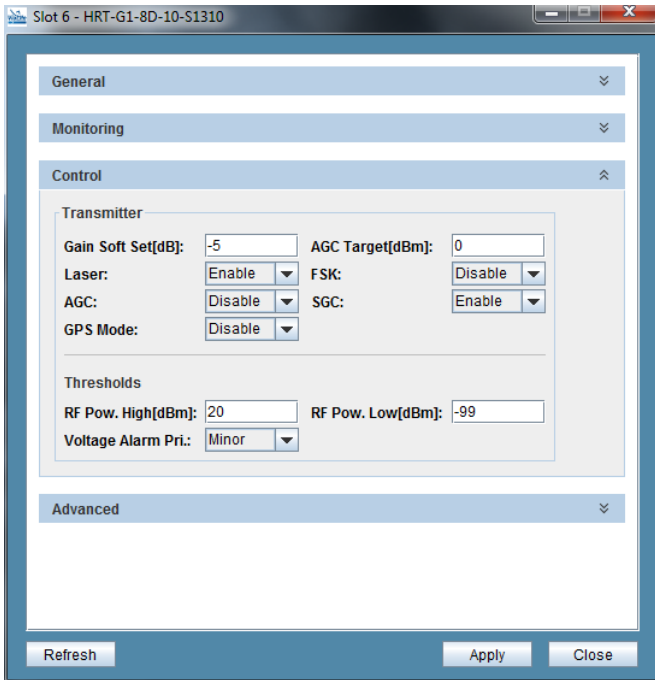

Slot window – TX type, control

Gain soft set – This sets the value of the set electro optic gain, measured in dB.

Laser – This sets the laser status, it can be enabled (on) or disabled (off).

AGC – This sets the automatic gain control status, it can be enabled (on) or disabled (off).

GPS mode - This sets the GPS emulation status, it can be enabled (on) or disabled (off).

AGC target – This sets the target value for the AGC control loop module, measured in dBm.

FSK – This sets the status of the frequency shift key digital communications channel, it can be enabled (on) or disabled (off).

SGC – This sets the software gain control status, it can be enabled (on) or disabled (off).

RF Pow. High(dBm) – Maximum RF power allowed before triggering a minor alarm.

RF Pow. Low(dBm) – Minimum RF power allowed before triggering a minor alarm.

Voltage Alarm Pri. – Priority of voltage alarm, can be either no alarm, minor alarm or major alarm.

7.2.2.1 Slot window for TX type, control, gain control priorities

There are a number of methods by which the gain may be controlled depending on module type. It is possible to make a number of them active simultaneously. In this case the module firmware will discriminate by order of priority.

Highest Priority	MGC, manual gain control set using module hardware switches, available on chassis modules.
	SGC, soft gain control, set via controller.
	AGC, Automatic gain control, set via controller.
Lowest Priority	Default gain, Factory pre-set gain.

The gain set by MGC is not reported through the control interface.

7.2.2.2 Slot window for TX type, control, enabling and disabling the laser

To change the laser status:

1. Left click slot GUI image, this will open the slot window.
2. Maximise the Control box.
3. Using the pull down menu change the status of the laser.
4. The desired status will now be shown in the box.
5. Click the apply button.
6. You will be asked to confirm the action, click yes if you are sure.
7. The change will take effect on the next polling cycle of the slot.
8. You can confirm that the change is in effect by opening the Monitoring box.

7.2.2.3 Slot window for TX type, control, turning on and off FSK

To change the FSK status:

1. Left click slot GUI image, this will open the slot window.
2. Maximise the Control box.
3. Using the pull down menu change the status of the FSK.

4. The desired status will now be shown in the box.
5. Click the apply button.
6. You will be asked to confirm the action, click yes if you are sure.
7. The change will take effect on the next polling cycle of the slot.
8. You can confirm that the change is in effect by opening the Monitoring box.

7.2.2.4 Slot window for TX type, control, turning on SGC and setting the soft gain

Note that the SGC settings will only be effective when BOTH the MGC switches are all set in the off position (factory default) AND the AGC status is disabled.

To change the SGC:

1. Left click slot GUI image, this will open the slot window.
2. Maximise the Control box.
3. Check that the AGC status is disabled, if not set it to disabled using the pull down menu.
4. Check that the SGC status is enabled, if not set it to enabled using the pull down menu.
5. You may hover over the Gain Soft Set box to determine the valid SGC range.
6. Enter the desired value into the Gain Soft Set box.
7. The desired status will now be shown in the box.
8. Click the apply button.
9. You will be asked to confirm the action, click yes if you are sure.
10. The change will take effect on the next polling cycle of the slot.
11. You can confirm that the change is in effect by opening the Monitoring box.

Note: The gain setting is rounded to closest 0.5dB step

7.2.2.5 Slot window for TX type, control, turning on AGC and setting the AGC target

Note that the AGC settings will only be effective when the MGC switches are all set in the off position (factory default).

To change the AGC:

1. Left click slot GUI image, this will open the slot window.
2. Maximise the Control box.
3. Check that the AGC status is enabled, if not set it to enabled using the pull down menu.
4. You may hover over the AGC Target box to determine the valid AGC range.
5. Enter the desired value into the AGC Target box.
6. The desired status will now be shown in the box.
7. Click the apply button.
8. You will be asked to confirm the action, click yes if you are sure.
9. The change will take effect on the next polling cycle of the slot.
10. You can confirm that the change is in effect by opening the Monitoring box.

Note: The gain setting is rounded to the closest 0.5dB step.

7.2.2.6 Slot window for TX type, control, calculating AGC target level

Variations in the input level can be compensated for by using transmitter AGC control. This can be used for two main purposes, either to fix the average RF output power or to control intermodulation products so that, for example, desired ratio of carrier to intermodulation distortions can be achieved.

The RF power is the level measured at the internal power detector and is dependent on the input signal level and gain control.

The AGC TARGET LEVEL is level that the module aims to achieve by gain control ahead of the internal detector. It can be set to a desired level so that RF MON will be locked to it with an accuracy of approx. 0.5dB when the AGC loop works normally.

To find out the value for AGC TARGET LEVEL when INPUT POWER is known, you may use the equation below

$$\text{AGC TARGET LEVEL} = \text{INPUT POWER} + \text{RF GAIN} - (\text{RF GAIN CAL} - \text{RF MON CAL})$$

Where RF GAIN is the real time monitor of TX GAIN, and RF GAIN CAL and RF MON CAL are the module factory calibration constants stored in the TX Type ADVANCED parameters box.

If the gain of the connected receiver is known, you may also relate the AGC TARGET LEVEL to the receiver OUTPUT POWER.

$$\text{AGC TARGET LEVEL} = \text{OUTPUT POWER} - \text{RF GAIN (RX)} - (\text{RF GAIN CAL} - \text{RF MON CAL}) + 2 \times \text{Optical Loss}$$

OR

$$\text{OUTPUT POWER} = \text{AGC TARGET LEVEL} + \text{RF GAIN (RX)} + (\text{RF GAIN CAL} - \text{RF MON CAL}) - 2 \times \text{Optical Loss}$$

7.2.2.7 Slot window for TX type, control, enabling and disabling GPS mode

Under normal non-fault condition a GPS TX FOL will operate in an identical fashion to all other ViaLiteHD modules. However the transmitter is equipped with additional hardware, this detects the DC current flowing from GPS transmitter RF input to the active GPS antenna. With GPS mode enabled, the transmitter laser will turn off if the antenna current falls to near zero. Full details are given in your RF modules handbook.

To change the GPS mode status:

1. Left click slot GUI image, this will open the slot window.
2. Maximise the Control box.
3. Check the GPS mode status; choose the desired status using the pull down menu.
4. The desired status will now be shown in the box.
5. Click the apply button.
6. You will be asked to confirm the action, click yes if you are sure.
7. The change will take effect on the next polling cycle of the slot.
8. You can confirm that the change is in effect by opening the Monitoring box.

7.2.3 Slot window for TX type, advanced

Note: Advanced parameters are for debugging only, and should not be accessed during normal usage.

Slot window – TX type, advanced

Bias set – This is the factory set laser power control loop DC target voltage, measured in millivolts.

Power cal – This is the factory optic monitor ADC calibration set point, measured in digital steps.

RF mon cal – This is the RF detector calibration, the ratio of internal measured to rear port power in Z0 ohms, measured in dB.

Monitor mask – This is a factory setting that can be used to mask some analogue alarms.

RF gain cal – This is a factory setting that can be used to calculating AGC thresholds, see section 7.2.2.6.

Power set – This is the factory set average laser power, measured in dBm.

Gain default – This is the factory set default gain for the module, measured in dB.

FSK freq set – This is the factory setting for the FSK tone frequency, measured in digital steps.

Events mask – This is a factory setting that can be used to mask some digital alarms.

7.3 Slot windows for TX type (DWDM)

DWDM laser equipped modules are similar to standard transmitter modules as described in section 7.2, but with some differences as detailed below.

Slot 6 - HRT-L1-8D-53-DC31

Part Number:	HRT-L1-8D-53-DC31
Type:	Transmitter DWDM LNB
FW Part Number:	ViaLiteHD 82041
FW Version:	110
FW Date:	25 Aug 15
Serial Number:	SN1245120
OEM Number:	T1
Customer ID:	None
Life Counter[H]:	0 Hour
Optical Wavelength [nm]	1550.52
Name:	

Monitoring

Control

LNB

Advanced

Refresh Apply Close

Optical Wavelength [nm] – The wavelength of the DWDM laser in nanometres.

7.3.1 Slow Window for TX type (DWDM), Monitoring

Slot 6 - HRT-L1-8D-53-DC31

Supply Voltage[V]:	12.1	Laser Bias[mA]:	77.6
Laser Power[dBm]:	7	RF Power[dBm]:	-28.4
RF Gain[dB]:	-11	RF Input[dBm]:	-41.3
Ext. Current[mA]:	0.9	Ext. Voltage[V]:	1.5
Laser Temp[Deg C]:	28.4	TEC Current[mA]:	344.6

Laser:	Enable	FSK Status:	Enable
MGC Status:	Off	AGC Status:	Disable
SGC Status:	Disable	GPS Status:	Off
TEC Dis Status:	Off		

Major Alarm:	Off	TEC Alarm:	Off
Bias Alarm:	Off	Laser Alarm:	Off

Minor Alarm:	On		
AGC Alarm:	Off	Power Alarm:	Off
Current Alarm:	Off	Temp. Alarm:	Off
Gain Alarm:	Off	VCC Alarm:	Off
Level Alarm:	Off	Voltage Alarm:	On

Refresh Apply Close

Laser Temp [Deg C] – The temperature of the laser in degrees centigrade. This depends on the wavelength of laser, but is generally around 30C.

TEC Current [mA] – The current drawn by the TEC (Thermo-electric cooler) in milliamps. This varies depending on the wavelength of laser and environmental conditions, but should be around +/-600mA.

TEC Dis Status – When on, the TEC is disabled.

Note: The TEC current can be negative, this occurs when ambient temperature is significantly below the target laser temperature and the TEC is used to heat it to operational temperature.

7.3.2 Slot Window for TX type (DWDM), Control

Slot 6 - HRT-L1-8D-53-DC31

General

Monitoring

Control

Transmitter

Gain Soft Set[dB]: -11 AGC Target[dBm]: 0

Laser: Enable FSK: Disable

AGC: Disable SGC: Disable

GPS Mode: Disable TEC Control: Enable

Thresholds

RF Pow. High[dBm]: 20 RF Pow. Low[dBm]: -99

Voltage Alarm Pri.: Minor

LNB

Advanced

Refresh Apply Close

TEC Control – Enables or disables the TEC (Thermo-electric cooler)

7.4 Slot windows for RX type

The RX type module will open with the General box maximised

Slot 7 - HRR-G1-8D-60-

General

Part Number: HRR-G1-8D-60-

Type: Receiver

FW Part Number: ViaLiteHD 82012

FW Version: 120

FW Date: 25 Apr 14

Serial Number: SN1240258

OEM Number: R1

Customer ID: None

Life Counter[H]: 72 Hours [3 Days 0 Hour]

Name:

Monitoring

Control

Advanced

Refresh Apply Close

7.4.1 Slot window for RX type, monitoring

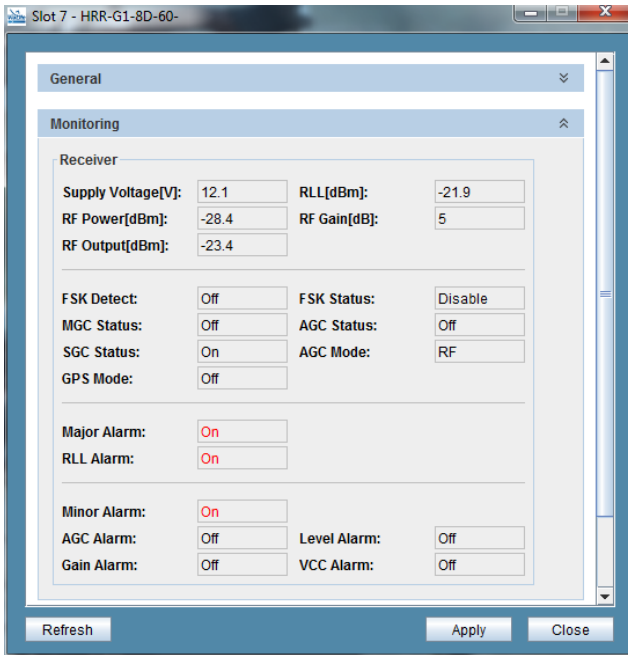

Slot window – RX type, monitoring

Supply Voltage – This is the supply voltage measured at the input to the module, measured in volts. Typical is around 12V.

RF Power – This is the RF power measured at the output of the final stage RF amplifier, measured in dBm.

RF Output – RF power measured at the RF connector.

RLL – Received light level, measured in dBm. Typical should be similar to the attached transmitter's laser power, but this value is affected by optical losses.

RF Gain – This is the electro optic gain of the module measured in dB. This is set by the SGC value.

FSK Detect - This shows if an FSK low speed digital carrier has been detected, it can on (carrier present) or off (no carrier).

MGC Status – This is the manual gain control status, it can on or off.

SGC Status – This is the software gain control status, it can on or off.

GPS Mode - This shows the status of the GPS mode, it can be on or off.

FSK Status –This is the frequency shift key digital communications channel status, it can be enabled (on) or disabled (off).

AGC Status – This is the automatic gain control status, it can be enabled (on) or disabled (off).

AGC Mode - This is the automatic gain control mode, it can be off or RLL or RF.

Major Alarm –This is the major alarm status, it can be on (alarm active) or off.

RLL Alarm – This is the received light level alarm status, it can be on (alarm active) or off.

Minor Alarm –This is the minor alarm status, it can be on (alarm active) or off.

AGC Alarm –This is the automatic gain control alarm status, it can be on (alarm active) or off.

Gain Alarm – This is the RF gain alarm status, it can be on (alarm active) or off.

Level Alarm –This is the RF power level alarm status, it can be on (alarm active) or off.

VCC Alarm –This is the (input) voltage alarm status, it can be on (alarm active) or off.

7.4.1.1 Slot window for RX type, monitoring, note on RX AGC modes

When set to operate in AGC mode the RX module can operate in either RLL or RF control mode.

When operating in RLL mode, the RX module will compensate for any optical loss by increasing the modules gain by 2dB of RF gain for each 1dB in reduction in received light level, from default 3mW (4.7dBm) optical output of a ViaLite transmitter. In this mode the AGC Target data is not required; any data value set in the AGC Target will be ignored. The gain is controlled in 0.5dB steps.

When operating in RF mode, the RX module will use a slow control loop to set the power at the monitor to the AGC Target level. The gain is continuously adjusted and is controlled in 0.5dB steps.

7.4.2 Slot window for RX type, control

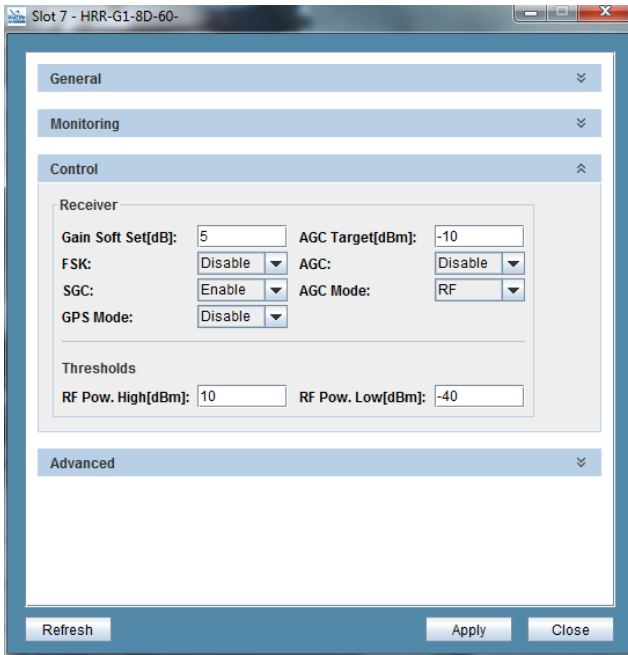

Slot window – RX type, control

Gain soft set – This sets the value of the set electro optic gain, measured in dB.

FSK – This sets the status of the frequency shift key digital communications channel, it can be enabled (on) or disabled (off).

SGC – This sets the software gain control status, it can be enabled (on) or disabled (off).

GPS mode – This sets the GPS load status, it can be enabled (on) or disabled (off).

AGC target – This sets the target value for the AGC control loop module, measured in dBm.

AGC – This sets the automatic gain control status, it can be enabled (on) or disabled (off).

AGC mode – This set the mode for the automatic gain, it can be driven by RLL (received light level) or RF (radio frequency) power.

RF Pow. High(dBm) – Maximum RF power allowed before triggering a minor alarm.

RF Pow. Low(dBm) – Minimum RF power allowed before triggering a minor alarm.

Voltage Alarm Pri. – Priority of voltage alarm, can be either no alarm, minor or major.

7.4.2.1 Slot window for RX type, control, gain control priorities

There are a number of methods by which the gain maybe controlled depending on module type. It is possible to make a number of them active simultaneously. In this case the module firmware will discriminate by order of priority.

Highest Priority MGC, manual gain control set using module hardware switches, available on chassis modules.
 SGC, soft gain control, set via controller.
 AGC, Automatic gain control, set via controller.

Lowest Priority Default gain, Factory pre-set gain.

The gain set by MGC is not reported through the control interface.

7.4.2.2 Slot window for RX type, control, turning on SGC and setting the soft gain

Note that the SGC settings will only be effective when both the MGC switches are all set in the off position (factory default) and the AGC status is disabled

To change the SGC:

1. Left click slot GUI image, this will open the slot window.
2. Maximise the Control box.
3. Check that the AGC status is disabled, if not set it to disabled using the pull down menu.
4. Check that the SGC status is enabled, if not set it to enabled using the pull down menu.
5. You may hover over the Gain Soft Set box to determine the valid SGC range.
6. Enter the desired value into the Gain Soft Set box.
7. The desired status will now be shown in the box.
8. Click the apply button.
9. You will be asked to confirm the action, click yes if you are sure.
10. The change will take effect on the next polling cycle of the slot.
11. You can confirm that the change is in effect by opening the Monitoring box.

Note: The gain setting is rounded to the closest 0.5dB step.

7.4.2.3 Slot window for RX type, control, turning on AGC and setting the AGC target

Note that the AGC settings will only be effective when the MGC switches are all set in the off position (factory default).

To change the AGC:

1. Left click slot GUI image, this will open the slot window.
2. Maximise the Control box.
3. Check that the AGC status is enabled, if not set it to enabled using the pull down menu.
4. Next choose the AGC Mode either RF or RLL.
5. You may hover over the AGC Target box to determine the valid AGC range.
6. Enter the desired value into the AGC Target box.
7. The desired status will now be shown in the box.
8. Click the apply button.
9. You will be asked to confirm the action, click yes if you are sure.
10. The change will take effect on the next polling cycle of the slot.
11. You can confirm that the change is in effect by opening the Monitoring box.

Note: The gain setting is rounded to the closest 0.5dB step.

7.4.2.4 Slot window for RX type, control, calculating AGC target level, RLL mode

The variations in received optical level can be compensated by using receiver AGC control in RLL mode. In this mode the receiver will compensate for optical loss by adjusting the modules RF gain, it will always try and mimic a zero loss optical link. In this AGC mode the AGC Target Level is not used.

In RLL mode you can either use the unit in its default gain setting or you may set a new gain by programming the desired soft gain with SGC enabled before enabling AGC and setting RLL mode.

In RLL mode, the AGC loop adjusts the RF gain automatically according to not the RF power, but the RLL value. If RLL is less than the default 4.5dBm, i.e., non-zero optical loss, the AGC loop will try to increase the gain so that the RF output level would be maintained.

This mode is useful if one wish to compensate for the optical loss to maintain a constant optical cable and receiver gain. RLL mode can be used in conjunction with transmitter RF mode AGC. This allows the optical loss to be automatically compensated.

If RLL gain control is active

$OUTPUT\ POWER = AGC\ TARGET\ LEVEL + RF\ GAIN\ (RX) + (RF\ GAIN\ CAL + RF\ MON\ CAL)$

7.4.2.5 Slot window for RX type, control, turning on and off FSK

Note 1: For the digital FSK channel to operate correctly the connected receiver and transmitter must have FSK capability

Note 2: The FSK control box is shown on modules with and without FSK digital channel, its status doesn't not affect modules not fitted with this feature.

To change the FSK status:

1. Left click slot GUI image, this will open the slot window.
2. Maximise the Control box.
3. Check the FSK status; choose the desired status using the pull down menu.
4. The desired status will now be shown in the box.
5. Click the apply button.
6. You will be asked to confirm the action, click yes if you are sure.
7. The change will take effect on the next polling cycle of the slot.
8. You can confirm that the change is in effect by opening the Monitoring box.

7.4.2.6 Slot window for RX type, control, enabling and disabling GPS mode

To change the GPS mode status:

1. Left click slot GUI image, this will open the slot window.
2. Maximise the Control box.
3. Check the GPS mode status; choose the desired status using the pull down menu.
4. The desired status will now be shown in the box.
5. Click the apply button.
6. You will be asked to confirm the action, click yes if you are sure.
7. The change will take effect on the next polling cycle of the slot.
8. You can confirm that the change is in effect by opening the Monitoring box.

7.4.3 Slot window for RX type, advanced

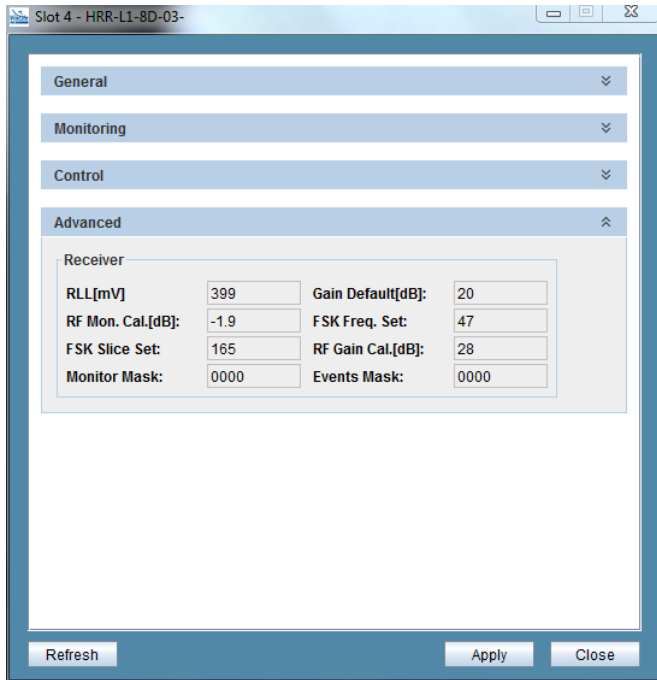

Note: Advanced parameters are for debugging only, and should not be accessed during normal usage.

Slot window – RX type, advanced

RLL – This is the factory calibration setting for RLL, measured in millivolts.

RF mon cal – This is the RF detector calibration, the ratio of internal measured to rear port power in Z0 ohms, measured in dB

FSK Slice set – This is the factory setting for the FSK decision level, measured in digital steps.

Monitor mask – This is a factory setting that can be used to mask some analogue alarms.

Gain default – This is the factory set default gain for the module, measured in dB.

FSK freq set – This is the factory setting for the FSK tone frequency, measured in digital steps.

RF gain cal – This is a factory setting that can be used to calculating AGC thresholds, see section 0.

Events mask – This is a factory setting that can be used to mask some digital alarms.

7.5 Slot windows for LNB type

Some types of single transmitter, dual transmitter and transceiver are equipped with LNB power supplies. The LNB supplies have their own control box in the TX type area. The LNB box can be expanded by clicking the arrow on the right of this box

7.5.1 Slot windows for LNB type, LNB

The LNB box contains both the monitors and controls for this function

Slot window – LNB type, monitoring

Overload alarm – This is the maximum output current status, it can be on (alarm active) or off .

Power Block- This is the power block status, it can be enabled (on) or disabled (off).

Output boost – This is the LNB voltage boost status, it can be enabled (+1V additional) or disabled (no extra voltage).

Voltage alarm – This is the voltage alarm status, it can be on (alarm active) or off.

Over temp. alarm – This is the over temperature alarm status, it can be on (alarm active) or off.

Output select – This is the output voltage status; it can be LOW (13V nominal) or HIGH (18V nominal).

Tone alarm – This is the tone alarm status, it can be on (alarm active) or off.

Current alarm – This is the minimum output current alarm status, it can be on (alarm active) or off.

Slot window – LNA type, control

AUX mode – This sets the auxiliary mode status, it can be on (22V nominal output) or disabled (normal).

Power block – This sets the power block status, it can be enabled (on) or disabled (off).

Output boost – This sets the output boost status, enabled (+1V additional) or disabled (no extra voltage).

Tone output - This sets the output tone status, on (22kHz tone) or off (no tone).

Current threshold – This sets the minimum current alarm threshold, it can be HIGH (12mA) or LOW (6mA)

Output select – This sets the output voltage selection, it can be LOW (13V nominal) or HIGH (18V nominal).

Tone gen. – This set the tone generation type, it can be Active (22kHz on) or DSQIN (do not use).

Current limit – This sets the current limit, it can be Static (simple current clamp) or Active (pulsed current limiting)

7.5.1.1 Slot windows for LNB type, LNB, changing mode

NOTE: The LNB control box will only be shown on units equipped with the correct hardware.

To change the LNB mode:

1. Left click slot GUI image, this will open the slot window.
2. Maximise the LNB box.

NOTE: The LNB box consists of both an upper Monitoring section and a lower Control section.

3. Check the LNB status; choose the desired status using the pull down menu in the Control section.
4. The desired status will now be shown in the box.
5. Click the apply button.
6. You will be asked to confirm the action, click yes if you are sure.
7. The change will take effect on the next polling cycle of the slot.
8. You can confirm that the change is in effect by looking in Monitoring section.

7.6 Slot windows for Serial Data type

The screenshot shows a software window titled "Slot 1 - HRB-1-00-8R-28-L1310". The window is divided into three main sections: "General", "Monitoring", and "Control".

General Section:

Part Number:	HRB-1-00-8R-28-L1310
Type:	Serial Data
FW Part Number:	ViaLiteHD 82017
FW Version:	111
FW Date:	10 Jul 14
Serial Number:	SN1240727
OEM Number:	X1
Customer ID:	NONE
Life Counter[H]:	3264 Hours [136 Days 0 Hour]
Name:	

Monitoring Section: (Currently collapsed)

Control Section: (Currently collapsed)

At the bottom of the window, there are three buttons: "Refresh", "Apply", and "Close".

7.6.1 Slot Windows for Serial Data type, Monitoring

Supply Voltage – The voltage supplied to the module in volts. This should be approximately 12V.

TTL Config – The input impedance in ohms.

RLL – The received light level in dBm.

Data Rate – The data rate in bits per second.

Laser Power – The output power of the laser in dBm.

Manual Status – The status of the manual override DIP switch on the module.

NOTE: If the manual override switch is set to on, manual settings will take priority over changes made in the GUI.

Major Alarm – Major alarm status.

Vcc Alarm – Input power alarm status.

RLL Alarm – Received light level alarm status.

Output select – This is the output voltage status; it can be Low (13V nominal) or High (18V nominal).

Minor Alarm – Minor alarm status.

Temp. Alarm – Temperature alarm.

7.6.2 Slot Windows for Serial Date type, control

Data Rate – The data rate in bits per second.

Laser Enable – The status of the laser.

TTL Config – The input impedance in ohms.

7.7 Slot windows for RF switch type

The RF switch is an active device, it has a window with General, Monitoring and a Control boxes.

Slot 5 - HRS-1-S1-0R-01

General	
Part Number:	HRS-1-S1-0R-01
Type:	Switch
FW Part Number:	ViaLite HD 82SW
FW Version:	100
FW Date:	04 Nov 10
Serial Number:	SN1032010
OEM Number:	SW
Customer ID:	DEMO
Life Counter[H]:	130988 Hours [14 Years 347 Da...]
Name:	

Monitoring

Control

Refresh Apply Close

7.7.1 Slot windows for RF switch type, monitoring

Slot 5 - HRS-1-S1-0R-01

Monitoring	
Mode Setting:	Preferred Left
Status:	Right ON
Major Alarm:	Off

Control

Refresh Apply Close

The monitoring box contains the following information:

Mode setting – This is the switching configuration in which is set.

Major Alarm – This shows the status of the alarm either off (good state) or on (alarm active).

Status – This shows which part the status of the switch either Left ON or Right ON (as viewed from front of chassis).

7.7.2 Slot windows for RF switch type, control

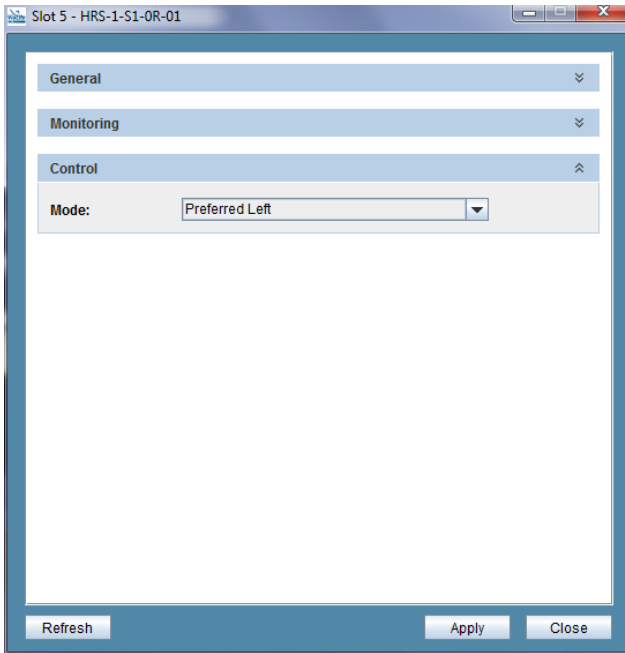

The control box contains the following settings:

Mode – This is the mode in which the switch is configured, the mode options are:

Preferred Left – The module is connected to the Left hand unit, if this unit alarm it will switch to the Right hand unit.

Preferred Right – The module is connected to the Right hand unit, if this unit alarm it will switch to the Left hand unit.

Forced Left – The module is connected to the Left irrespective of alarm status.

Forced Right – The module is connected to the Right irrespective of alarm status.

By default all switches are delivered set to Preferred Left.

Left and Right are reference to the front view of the chassis.

7.7.2.1 Slot windows for switch type, change mode

To change the switch mode:

1. Left click on the switches GUI image, this will open the slot window.
2. Click the arrow on the right of the control box to maximise this box.
3. Now select the desired mode from the mode pull down menu.
4. After having selected the mode, click on the windows apply button.
5. You will be asked to confirm the action, click yes if you are sure.
6. The change will take effect on the next polling cycle of the slot.
7. You can confirm that the change is in effect by opening the Monitoring box and checking the Mode Setting.

7.8 Slot windows for Splitter type

The RF splitter is a passive device, it has a window with General box but no control functions.

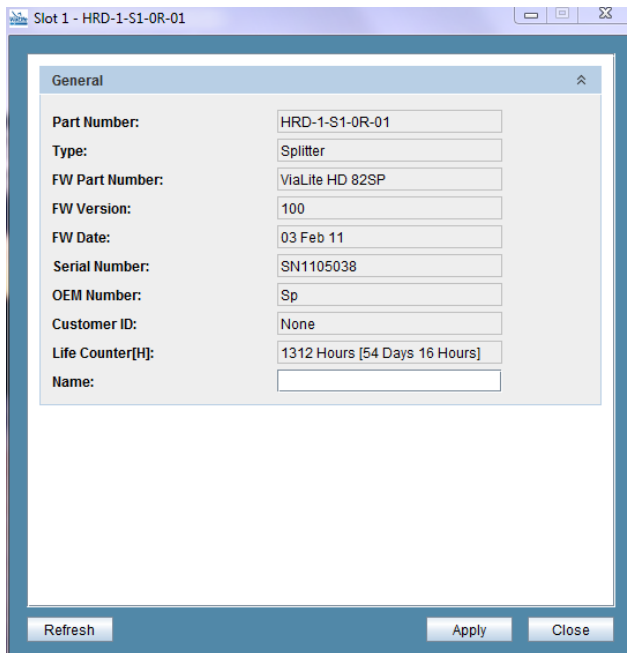

Slot 1 - HRD-1-S1-0R-01

General	
Part Number:	HRD-1-S1-0R-01
Type:	Splitter
FW Part Number:	ViaLite HD 82SP
FW Version:	100
FW Date:	03 Feb 11
Serial Number:	SN1105038
OEM Number:	Sp
Customer ID:	None
Life Counter[H]:	1312 Hours [54 Days 16 Hours]
Name:	

Refresh Apply Close

7.9 Slot windows for Frequency source type

The Frequency source module is not controllable, it has a window with General box but no control functions.

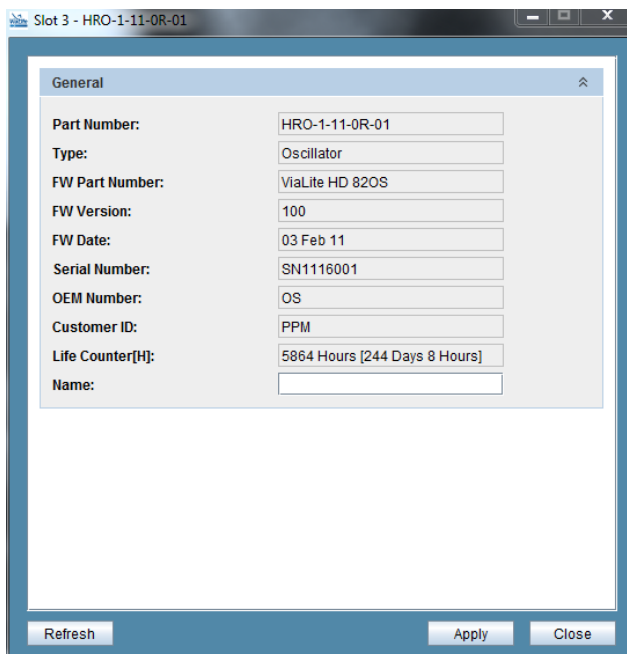

Slot 3 - HRO-1-11-0R-01

General	
Part Number:	HRO-1-11-0R-01
Type:	Oscillator
FW Part Number:	ViaLite HD 82OS
FW Version:	100
FW Date:	03 Feb 11
Serial Number:	SN1116001
OEM Number:	OS
Customer ID:	PPM
Life Counter[H]:	5864 Hours [244 Days 8 Hours]
Name:	

Refresh Apply Close

7.10 Slot windows for Redundancy load type

The redundancy load module has no active components or microprocessor. It will not be shown on the GUI and has no control window.

7.11 Slot windows for Amplifier type

The RF amplifier is an active device; it has a window with General, Monitoring, Control, and Advanced boxes.

Slot 2 - HRA-2-S1-0R-02

General

Part Number: HRA-2-S1-0R-02

Type: Amplifier

FW Part Number: ViaLite HD 82AM

FW Version: 100

FW Date: 06 -an -1

Serial Number:

OEM Number:

Customer ID:

Life Counter[H]: 690 Hours [28 Days 18 Hours]

Name:

Monitoring

Control

Advanced

Refresh Apply Close

7.11.1 Slot window for Amplifier type, monitoring

Slot 2 - HRA-2-S1-0R-02

General

Monitoring

Supply Voltage[V]: 0 Temperature[*C]: 0

Amp1 RF Power[dBm]: -27.4 Amp2 RF Power[dBm]: -30

Amp1 RF Gain[dB]: 14.5 Amp2 RF Gain[dB]: 14.5

Amp1 MGC Status: On Amp2 MGC Status: On

Amp1 AGC Status: Off Amp2 AGC Status: Off

Major Alarm: Off

Minor Alarm: Off

Amp1 AGC Alarm: Off Amp2 AGC Alarm: Off

Amp1 Gain Alarm: Off Amp2 Gain Alarm: Off

Amp1 Level Alarm: Off Amp2 Level Alarm: Off

Temp. Alarm: Off VCC Alarm: Off

Control

Refresh Apply Close

Slot window – Amplifier type, monitoring

*Supply Voltage** - This is the supply voltage measured at the input to the module, measured in volts. Typical is around 12V.

*Temperature** – This is the board temperature in degrees centigrade.

Amp X RF power – This is the RF power of amplifier X measured in dBm at the output.

*Amp X RF gain*** – This is the RF gain of amplifier X measured in dB.

AMP X MGC status – This is the manual gain control (via DIP switches) alarm status, it can be on or off.

Amp X AGC status – This is the automatic gain control alarm status, it can be on or off.

Major Alarm – This is the major alarm status, it can be on (alarm active) or off.

*Vcc Alarm** – This is the (input) voltage alarm status, it can be on (alarm active) or off.

Minor Alarm - This is the minor alarm status, it can be on (alarm active) or off.

*Temp Alarm** - This is the temperature alarm status, it can be on (alarm active) or off.

*Amp X AGC alarm** – This is the RF power level alarm status, it can be on (alarm active) or off.

Amp X level alarm – This is the RF power level alarm status, it can be on (alarm active) or off.
Amp X gain alarm – This is the RF gain alarm status, it can be on (alarm active) or off.

* These are future features; the data in these fields are not currently valid.

** When MGC control is enabled (via DIP switches) these reported values are not valid.

7.11.2 Slot window for Amplifier type, control

Slot window – Amplifier type, control

*Amp X Gain soft set** – This sets the value of the gain, measured in dB

*Amp X AGC target** – This sets the target value for the AGC control loop module, measured in dBm.

*Amp X AGC control** – This sets the software automatic gain control status, it can be enabled (AGC on) or disabled (AGC off).

Amp X Th High – This sets the output power high MAJOR alarm threshold, measured in dBm

Amp X Th low – This sets the output power low MAJOR alarm threshold, measured in dBm

Th Gain Alarm – This sets the gain alarm offset between MINOR and MAJOR alarm, measured in dB.

Th level Alarm – This sets the level alarm offset between MINOR and MAJOR alarm, measured in dB.

** When MGC control is enabled (via DIP switches) it takes priority over soft set and AGC

7.11.2.1 Slot windows for Amplifier type, alarm threshold example

If TH. GAIN ALARM is set to 0:

- MAJOR and MINOR alarms will occur at 15dB or lower gain or at 30dB or higher gain.

If TH. GAIN ALARM is set to 3:

- MINOR alarms will occur at 18dB or lower gain or at 27dB or higher gain
- MAJOR alarms will occur at 15dB or lower gain or at 30dB or higher gain

If AMP1 TH HIGH is set to 10 and AMP1 TH LOW is set to -10 and TH. Gain Alarm is set to 0:

- MAJOR and MINOR alarms will both occur at -10dBm or lower power or at +10dBm or higher power.

If AMP1 TH HIGH is set to 10 and AMP1 TH LOW is set to -10 and TH. Gain Alarm is set to 3:

- MINOR alarms will occur at -7dBm or lower power or at +7dBm or higher power
- MAJOR alarms will occur at -10dBm or lower power or at +10dBm or higher power

7.11.2.2 Slot windows for Amplifier type, change AGC mode

To change the amplifier AGC mode:

1. Left click on the amplifiers GUI image, this will open the slot window.
2. Click the arrow on the right of the Control box to maximise this box (you may also minimise the General box).
3. Now select the desired mode from the mode pull down menu.
4. After having selected the mode, click on the windows apply button.
5. You will be asked to confirm the action, click yes if you are sure.
6. The change will take effect on the next polling cycle of the slot.
7. You can confirm that the change is in effect by opening the Monitoring box and checking the Mode setting.

7.11.2.3 Slot windows for Amplifier type, change control values

To change the control values these may be any of:

- Amp X Gain soft set
- Amp X AGC target
- Amp X AGC
- Amp X Th High
- Amp X Th low
- Th Gain Alarm
- Th level Alarm.

1. Left click on the amplifiers GUI image, this will open the slot window
2. Click the arrow on the right of the Control box to maximise this box (you may also minimise the General box)
3. You may hover over the box to determine the valid range of values
4. Enter the desired value into the box.
5. After having typed the value, click on the windows apply button
6. You will be asked to confirm the action, click yes if you are sure
7. The change will take effect on the next polling cycle of the slot
8. You can confirm that the change is in effect by opening the Monitoring box and checking the Mode setting

7.11.3 Slot window for Amplifier type, advanced

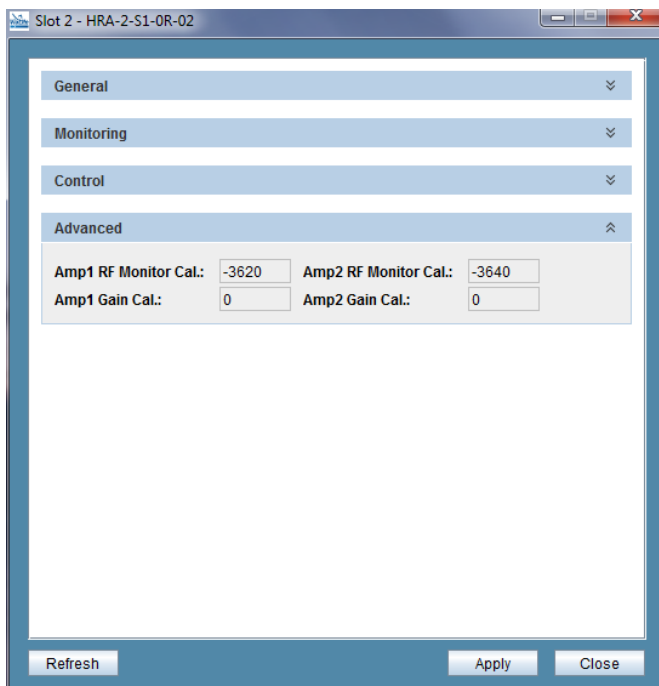

Note: Advanced parameters are for debugging only, and should not be accessed during normal usage.

Slot window – Amplifier type, advanced

Amp X RF monitor cal – This is a factory set calibration value

Amp X gain cal – This is a factory set calibration value

7.12 Slot Window for Ethernet type

Slot 9 - HRE-2-09-8R-02-S1550

General	
Part Number:	HRE-2-09-8R-02-S1550
Type:	Ethernet
FW Part Number:	ViaLiteHD 82021
FW Version:	103
FW Date:	23 Apr 14
Serial Number:	SN1218553
OEM Number:	MC
Customer ID:	NONE
Life Counter[H]:	0 Hour
Name:	

Monitoring

Refresh Apply Close

7.12.1 Slot Window for Ethernet type, Monitoring

Slot 9 - HRE-2-09-8R-02-S1550

General	
Part Number:	HRE-2-09-8R-02-S1550
Type:	Ethernet
FW Part Number:	ViaLiteHD 82021
FW Version:	103
FW Date:	23 Apr 14
Serial Number:	SN1218553
OEM Number:	MC
Customer ID:	NONE
Life Counter[H]:	0 Hour
Name:	

Monitoring			
Fiber Activity:	Inactive	Fiber Link:	
Copper 1 Activity:	Inactive	Copper 1 Link:	
Copper 2 Activity:	Inactive	Copper 2 Link:	
Copper 3 Activity:	Inactive	Copper 3 Link:	
Alarm:	On		

Refresh Apply Close

Slot window – Ethernet type, monitoring

Fiber Activity – Shows activity on fiber link

Copper 1 Activity – Shows activity on copper 1

Copper 2 Activity – Shows activity on copper 2

Copper 3 Activity – Shows activity on copper 3

Fiber Link – Shows status of fiber link

Copper 1 Link – Shows status of copper 1 link

Copper 2 Link – Shows status of copper 1 link

Copper 3 Link – Shows status of copper 1 link

Alarm – Alarm status

8 Software Update

8.1 Software Update – GUI Method

To upload new software to the SNMP card:

1. Left click the Software Update icon on the left hand bar.
2. Click the arrow on the right of Operation to maximise this box.
3. Click the arrow on the right of File Server to maximise this box.
4. Take note of your FTP server details (if using a central server). If setting up a temporary FTP server used only for the duration of the software update, a standalone FTP server such as ftpdmin is recommended. This can be downloaded from <http://www.sentex.net/~mwandel/ftpdmin/>.
5. Place the software file in your C:/ drive and run ftpdmin. The software can be found in the “Downloads” section of the Vialite website.
6. You will see a command line window appear with text similar to below.

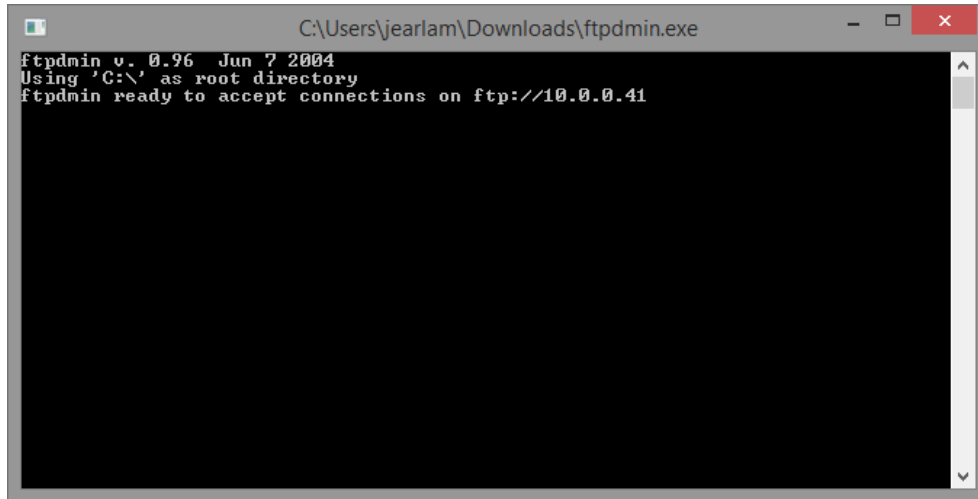

```

C:\Users\jearlam\Downloads\ftpdmin.exe
ftpdmin v. 0.96 Jun 7 2004
Using 'C:\' as root directory
ftpdmin ready to accept connections on ftp://10.0.0.41

```

7. Enter the IP address from the command window into the software update window. Leave the username and password fields blank.

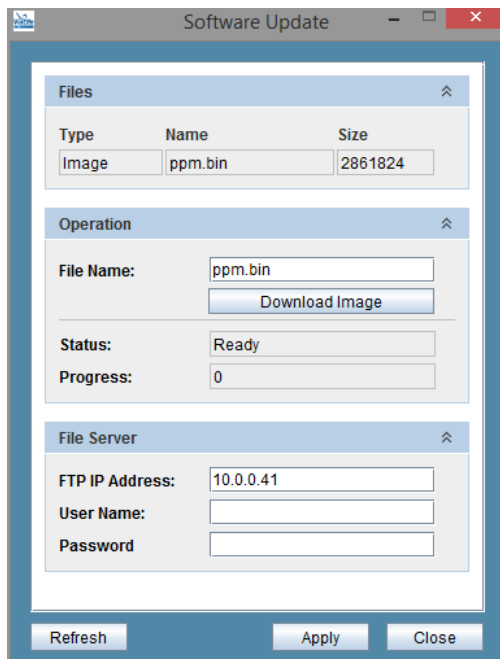

8. Enter the file name of the software file into the File Name box.
9. Press the apply button at the bottom of the window to apply the settings.
10. **Recheck all the details: It is possible to corrupt the board if an incorrect image is loaded.** This may require a factory reset.
11. Press the Download Image button.
12. You will be asked to confirm the action, click yes if you are sure.
13. You will see the upload start, progress and complete.
14. Typically it will take about 2 minutes but is very dependent on your network.

15. When the status window says Ready, the new software is loaded. You can now close the ftpdmin window.
16. To restart the GUI you **must** close the close ALL the web browser windows in which it is running.
17. Open a new web browser window.
18. You may confirm the version by clicking the left hand menu System icon and opening the Inventory box.

8.2 Software Update – Serial Cable Method

While using the GUI to update the software is recommended, sometimes it is preferable to use the serial interface.

Enter the Software Menu as per section 4. This menu allows the user to download new software and to set SNMP communities.

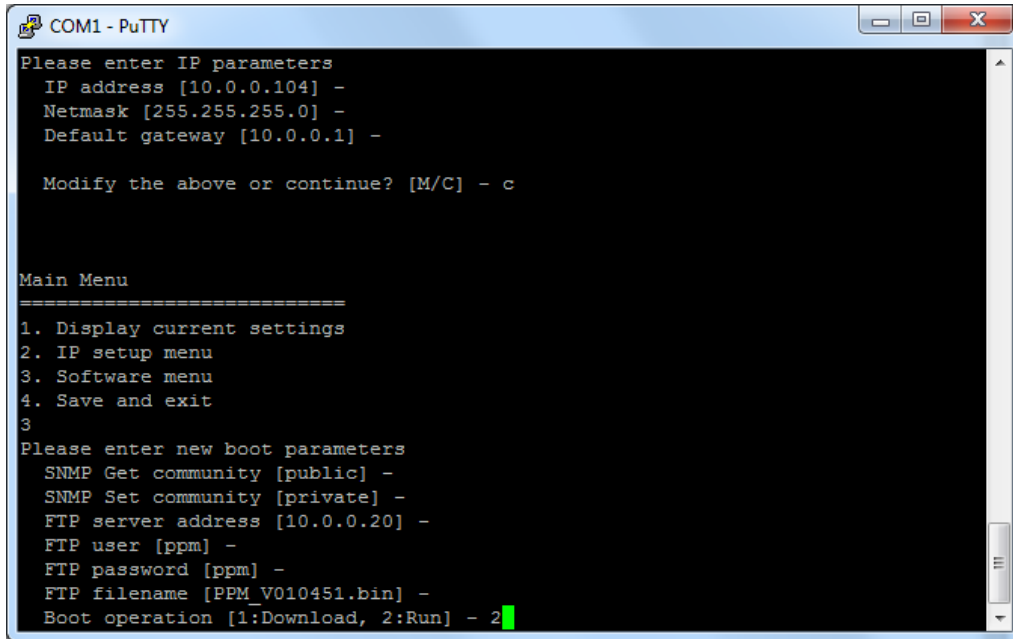
A screenshot of a PuTTY terminal window titled 'COM1 - PuTTY'. The terminal displays a text-based menu for software updates. The menu is as follows:

```
Please enter IP parameters
IP address [10.0.0.104] -
Netmask [255.255.255.0] -
Default gateway [10.0.0.1] -

Modify the above or continue? [M/C] - c

Main Menu
=====
1. Display current settings
2. IP setup menu
3. Software menu
4. Save and exit
3
Please enter new boot parameters
SNMP Get community [public] -
SNMP Set community [private] -
FTP server address [10.0.0.20] -
FTP user [ppm] -
FTP password [ppm] -
FTP filename [PPM_V010451.bin] -
Boot operation [1:Download, 2:Run] - 2
```

Note that software upgrade requires a network connection and cannot be done only using the serial port: the serial port is used only to set correct parameters for initial operation. The file to download has to be loaded to computer running an FTP server, see section 8.1 for details on setting up an FTP server.

Note that downloading of incorrect files can prevent the unit from running and will require a factory upgrade.

In order to upgrade the software, set the FTP server name, username and password, as well as the name of the software file. If you wish to leave a value unchanged, press enter when prompted for the new value. Once the values have been input correctly, choose 1 when prompted to download the new software version. After the download has finished, go to the Software menu and choose 2 to run the software.

9 **System Integration**

9.1 **Initial set up equipment**

For initial set up and programming you will require:

- A computer with serial control port (9 way D type, DB9) running PuTTY or similar software in serial mode.
- PPM supplied serial interface cable.
- A computer with 10/100 Ethernet port, running PuTTY or similar software in Telnet mode.
- Suitable chassis to mount the target SNMP and web controller module, while performing this task.

Full set up details are given in section 4 and 5.

9.2 **Site requirements**

The site will require the following services, to make full use of the SNMP and web controllers features:

- A computer with Java enabled web browser to use the web interface.
OR
- Computer running SNMP management package.
- Suitable mounting environment for chassis.
- Power source for chassis.
- Copper and optical cabling as required, with appropriate interfaces to terminate these to.
- LAN unless the module is only to be locally controlled.
- Network identification values that should be allocated by the network administrator are:
 - IP Address for the SNMP and web controller module.
 - IP Address for the NMS station.
 - Netmask.
 - Gateway Address.

9.3 **Other considerations, RJ45 interconnection**

The SNMP and web controller module is fitted with multiple RJ45 connections and an internal switch. This may therefore be used to:

- Connect to other customer peripheral equipment with Ethernet interfaces.
- To daisy chain multiple SNMP and web controller modules, reducing the requirement for LAN connections.

9.4 **ViaLiteHD trap file**

- The latest trap and MIB definition files can be found under the "MIB Files" link on the Vialite website - <http://www.vialite.com/software.php>.

The ViaLite HD chassis can be located in the MIB tree at OID 1.3.6.1.4.1.31225.1.1. The full path is: iso(1).org(3).dod(6).internet(1).private(4).enterprises(1).ppm(31225).ppmProducts(1).ignis(1)

Refer to the MIB file in order to find more details. The file contains detailed comments explaining the meaning of all parameters along with possible values.

There are 13 slots and any of the slots can support different units either single or dual. In case of optical modules following configurations are available:

- Single transmitter – use parameters starting with modTx1 to access the unit.
- Single receiver – use parameters starting with modRx1.
- Dual receiver – use modRx1 to access upper receiver and modRx2 for lower one.
- Dual transmitter – use modTx1 to access upper transmitter and modTx2 for lower one.
- Transceiver – use modTx2 to access transmitter and modRx1 to access receiver.
- Single amplifier - use modAmp2 to access the first (input) stage of the amplifier and modAmp1 to access the second (output) stage of the amplifier.
- Dual amplifier - use modAmp1 to access the upper amplifier and modAmp2 to access the lower amplifier.
- Splitter, Switches and LNB power supplies are always single modules.

10 Mechanical Dimensions

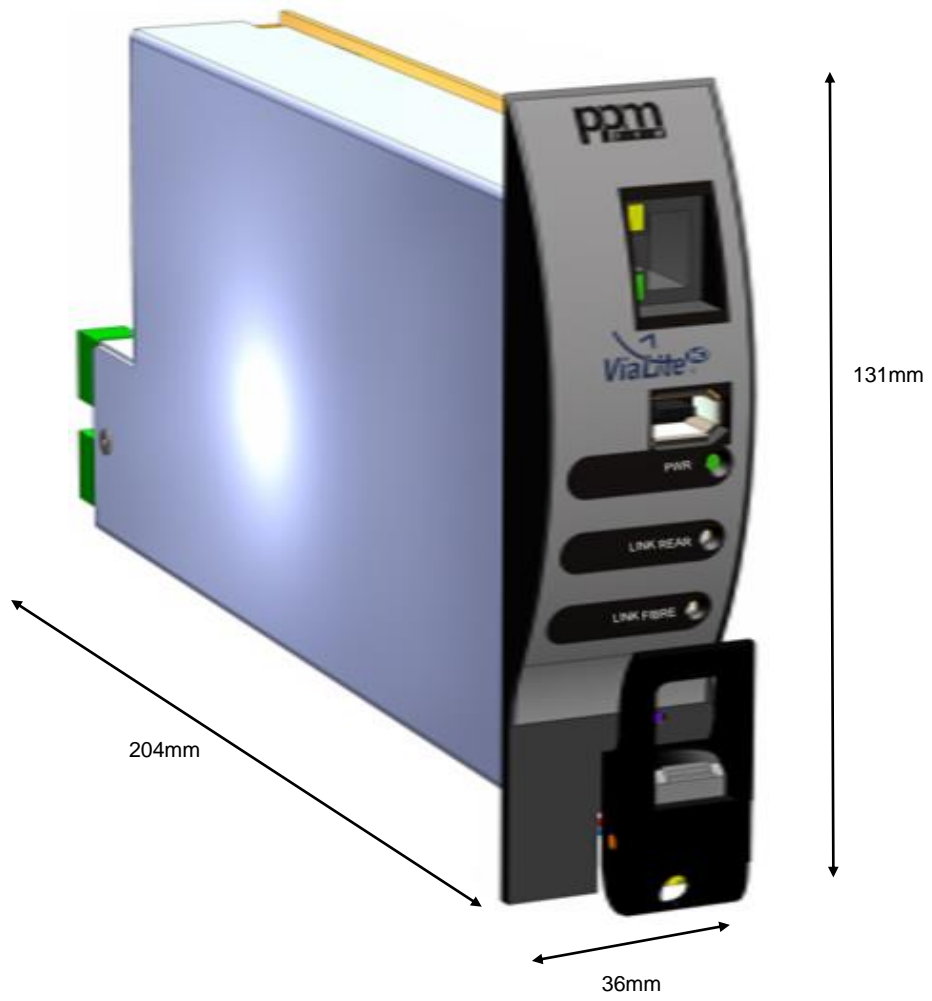

Weight: 255g Typical

11 **Part Numbering**

For part numbering please refer to the relevant datasheet which can be found on our website or contact us.

12 Technical Specifications

Module function	Controller card with Ethernet switch
Format	Plug in module compatible with ViaLiteHD chassis, 7HP slot
Indicators	Front Panel LED "Power (RED/GREEN)" Front Panel LED "Rear RJ45 LINK (GREEN)" Front Panel LED "Rear Fibre LINK (GREEN)" RJ45 LED each with ACTIVITY (AMBER) and LINK (GREEN)
Electrical signal/power connector	Plug-in module, user accessible via 19" Chassis backplane

Operating Conditions

Module operating voltage	+12V \pm 0.5V
Module operating voltage and power	4W Typical
Operating temperature	-10°C to +50°C
Storage temperature	-40°C to +70°C
Ambient relative humidity	10% to 95% (Non Condensing)
Maximum weight	300g

Ethernet ports, Copper

Data rate, RJ45 ports	10/100 MB/s (auto negotiating)
Network standards	Fast Ethernet IEEE 802.3u (100BASE-TX)

Ethernet port, Optical

Data rate, fibre port	100 MB/s
Output power	-11dBm typical, Class 1
Wavelength	1310 \pm 50nm
Fibre	Singlemode 9/125, Corning SMF28 or equivalent
Optical connector	2 * FC/APC or 2 * SC/APC
Optical path length	0m to 20km for 1310nm, with single-mode fibre
Optical power budget	>10dB (Typical fibre losses: Fibre: 0.4dB/km; Connectors: 0.5dB max.)

Craft port

Connector type	Firewire, 6 circuit connector (IEE1394)
Serial interface cable	Compatible with PPM part number 73706, supplied with each unit
Serial data type	RS232, 9600 bps, 8 data bits, 1 stop bit, no parity, no flow control

Relay

Relay Type	Form C break before make, dry contact, volt free
Relay ports	RELAY_ [1= normally closed, 2=common, 3=normally open] COM (common) Available on chassis connector NO (normally open) Available on chassis connector NC (normally closed) Available on chassis connector
Maximum voltage & current	50V @1A, all voltages are relative to ground
Initial contact resistance	75 m Ω

Software interfaces

SNMP agent	Supports SNMP version 1 and version 2C
MIB	ViaLite proprietary MIB, RFC1213 compliant, supports MIB-II "system" group

13 Maintenance and Fault-Finding Guide

Refer to the following table that gives a list of commonly encountered problems and suggested solutions.

Fault	Possible Causes	Solution
PWR LED does not light	Power source not connected.	Connect power source.
PWR LED is RED	A connected modules has a major alarm	If this is normal behaviour Fix alarming module
LINK FIBRE LED does not light	Module and remote fibre, not correctly connected	Check that Fibres are correctly connected and not swapped
	Dirty Fibre	Clean Fibres then reconnect
Module not accessible via Ethernet	Ethernet cable not connected	Connect the Ethernet cable
	Wrong IP settings	Set right IP values in consultation with your network administrator
	Module in configuration mode	Disconnect configuration cable, reset the unit
GUI not displayed	Module in configuration mode	Reset the unit or set to RUN mode via serial
	IP setting not correct	Use configured module IP address
	Java engine not installed or running	Install and run Java
	PC configuration IP set up incorrect	Correct PC set up
	Internal fault	Consult local PPM office.

The **ViaLiteHD** range is precision engineered and calibrated for optimum performance and accuracy before dispatch.

In the event of any problems or queries arising with the equipment, please contact **ViaLite** or your local agent.

14 Glossary

A	Ampere
AGC	Automatic gain control
BUC	Block up converter
CNR	Carrier to noise ratio
COM	Common
dB	Decibel
dBc	Decibel relative to carrier
dBm	Decibel milliwatt
DC	Direct current
DHCP	Dynamic host configuration Protocol
DIP	Dual in line (package)
DVB	Digital video broadcast
DVB-T	Digital video broadcast terrestrial
FC/APC	Fibre connector angled polished contact
FC/PC	Fibre connector physical contact
FOL	Fibre optic link
FSK	frequency shift keying
FTP	File transfer protocol
g	Gram
GHz	Giga hertz
GPS	Global positioning system
GRN	Goods Return Number
GUI	Graphical user interface
HRK3	ViaLiteHD 3U chassis
HTML	Hypertext mark-up language
HP	Chassis hole pitch measurement of width 5.08mm
Hz	Hertz
I2C	Inter-Integrated circuit bus
IMD	Intermodulation distortion ratio
IP	Internet protocol
IP3	Third order intercept point
kg	Kilo gram
kHz	Kilo hertz
LAN	Local area network
LASER	Light amplification by stimulated emission of radiation
LC/PC	Lucent connector physical contact
LED	Light emitting diode
LNA	Low noise amplifier
LNB	Low noise block
m	Metre
mA	Milli ampere
Max	Maximum
MHz	Mega hertz
Min	Minimum
mm	Milli metre
mV	Milli volt
NC	Normally closed
NF	Noise figure
nm	Nano meter
NO	Normally open
P1dB	Power at one decibel gain compression
PC	Personal computer
PPM	Pulse power and measurement Ltd
PWR	Power
RF	Radio frequency
RLL	Received light level
RST	Reset
RX	Receiver
SC/APC	Subscriber connector angled polished contact
SC/PC	Subscriber connector physical contact
SFDR	Spurious free dynamic range
SINAD	Signal to noise and distortion ratio
SNMP	Simple network management protocol
TCP/IP	Transmission Control Protocol
TRX	Transceiver
TX	Transmitter
Typ	Typical
U	Rack units measurement of height 44.45mm
V	Voltage select
VSEL	Voltage select
VSWR	Voltage standing wave ratio
W	Watt

15 Product Warranty

The guarantee / warranty period, unless otherwise agreed in writing, shall be as stated in document F292 - PPM Manufactured Product – Warranty, which is available at: <https://ppm.co.uk/warranty-periods/>. Extended warranty options are available at the time of purchase.

Prior to returning any goods for warranty or non-warranty repairs please contact PPM / **ViaLite Communications** for a returns reference.

16 FCC Approval

Information to the user of **ViaLiteHD** products

For a Class A digital device or peripheral, the following instructions are furnished to the user. This equipment has been tested and found to comply with the limits for a Class A digital device, pursuant to part 15 of the FCC Rules. These limits are designed to provide reasonable protection against harmful interference when the equipment is operated in a commercial environment. This equipment generates, uses, and can radiate radio frequency energy and, if not installed and used in accordance with the instruction manual, may cause harmful interference to radio communications. Operation of this equipment in a residential area is likely to cause harmful interference in which case the user will be required to correct the interference at his own expense.

© PULSE POWER & MEASUREMENT LTD 2020

NO PART OF THIS DOCUMENT MAY BE REPRODUCED OR TRANSMITTED IN ANY FORM WITHOUT PRIOR WRITTEN PERMISSION.

PULSE POWER & MEASUREMENT LTD, 65 SHRIVENHAM HUNDRED BUSINESS PARK, SWINDON, SN6 8TY, UK.

TEL: +44 1793 784389 FAX: +44 1793 784391

EMAIL: SALES@VIALITE.COM WEBSITE : WWW.VIALITE.COM