

Outdoor enclosure type MINI ODE-MINI

User Guide

HMA-HB-4

CR5638

04/12/2023



Instrument Care and Safety Information

Please read the whole of this section before using your **ViaLiteHD** product. It contains important safety information and will enable you to get the most from your Fibre Optic link.

Electrical Safety



The **ViaLiteHD** enclosure is a Safety Class 1 product (having metal chassis directly connected to earth via the power cable).

When operating the equipment note the following precautions:

- Hazardous voltages exist within the equipment.
- ODE-MINI's may be fitted with user configurable items. These configurable items can only be adjusted by skilled persons and this must be done with the ODE-MINI de-energised and disconnected from the mains supply.
- There are replaceable fuses inside the casing. Replacement should only be carried out by a PPM technician.
- The chassis earth stud SHOULD be connected to the safety earth.
- When using a 2 pin power supply cable the chassis earth stud MUST be connected to the safety earth.
- The **ViaLiteHD** Power Supply Modules do not have an isolating switch on the mains voltage inlet. For this reason, the **ViaLiteHD** chassis MUST be installed within easy reach of a clearly labelled dual pole mains isolation switch supplying the equipment.
- PSU modules are fused on the mains live feed only. A second fuse should be used for the neutral connection where the polarity of the connectors can be reversed; rating should match those given in section 2.13.
- The ODE-MINI is Class II overvoltage category of powered via the normal building installation wiring.

ESD Precautions



Precautions for handling electro-static sensitive devices should be observed when handling all **ViaLite** modules. Technicians should ensure that they use effective personal grounding (i.e. ESD wrist strap etc.) when servicing the equipment. Any equipment or tools used should be grounded to prevent static charge build-up. Good practice should be observed at all times. For reference see relevant standards.

EN 61340-5-1, "Protection of Electronic Devices from Electrostatic Phenomena – General Requirements"

Optical Safety



The **ViaLite** RF Transmitter and Transceiver modules contain laser diode sources operating at nominal wavelengths of 1270nm to 1610nm.

These devices are rated as EN60825-1 CLASS 1 radiation emitting devices. A class 1 laser is safe under all conditions of normal use.

When operating the equipment note the following precautions:

- Never look into the end of an optical fibre directly or by reflection either with the naked eye or through an optical instrument.
- Never leave equipment with radiating bare fibres – always cap the connectors.
- Do not remove equipment external covers when operating.

Hot surface



The **ViaLite** systems may have hot surfaces when operating under full load. The hot surfaces are not accessible when fitted in an approved chassis installation. Hot surfaces will be appropriately marked

Suitable precaution should be taken when handling this device.

- Allow to cool for 10 minutes
- Do not touch metallic surfaces or printed circuit board when hot.
- When handling, hold front panel and handle only.

TABLE OF CONTENTS

1	INTRODUCTION	5
1.1	Typical deployment.....	5
1.2	<i>ViaLiteHD</i> compatibility.....	5
1.3	Care of fibre optic connectors.....	5
1.4	Fibre optic cable & connectors	6
1.4.1	Connector and cable types.....	6
1.4.2	Connecting and disconnecting	6
1.4.3	Cleaning optical connectors, cleaning before every use.....	6
1.4.4	Cleaning optical connectors, high levels of contamination	6
1.4.5	SC/APC Connectors.....	7
1.4.6	Minimum bend radius	7
2	SETTING UP THE ODE-MINI.....	8
2.1	ODE-MINI external features	8
2.1.1	Humidity control/ventilator gland	8
2.2	Weatherproof interface connections.....	9
2.3	Mounting the ODE-MINI	10
2.3.1	Using the 70004-2 wall mounting bracket kit	10
2.3.2	Using the 70004-(60MINI) (90MINI) (110MINI) pole mounting kit	10
2.4	Lightning Suppressor.....	11
2.5	Antennas.....	12
2.6	Termination of RF Connections.....	12
2.7	Termination of power	13
2.8	Termination of Optical fibre	14
2.9	LNB Voltage selection	15
2.9.1	LNB Customer variable voltage source.....	16
2.9.2	LNB Voltage tolerance	17
2.10	High voltage or high power LNB/BUC supply options	17
2.11	ODE-MINI power supplies	17
2.12	Replacement of Power Supply Modules	18
2.13	ODE-MINI replaceable fuse.....	18
3	PRODUCT WARRANTY.....	19
4	FCC APPROVAL	20

1 Introduction

The Outdoor Enclosure type MINI (ODE-MINI), is a cost-effective weatherproof enclosure for **ViaLiteHD** systems and associated hardware. It is intended to service the requirements of most GPS timing and satellite communication systems though can be configured to suit a wide range of other applications.

The ODE-MINI system is comprised of the following key parts:

- IP-65 rated external enclosure fitted with:
- Dual power supplies (redundancy or power sharing)
- Capacity for up to two **ViaLiteHD** OEM modules with front panel connections
- Termination of input power cable (inside the supplied quick release latching connector)
- Patch box for termination of optical cable (various quad fibre cable lengths available)
- Connectorised RF inputs / outputs.

It has a wide range of optional accessories including:

- Lightning suppressor(s)
- Optical cable
- Wall or pole mount fixings.

ViaLiteHD RF Fibre Optic Links (FOLs) are a family of fibre optically coupled link systems designed for the transmission of RF analogue signals over long distances for the communications market.

ViaLite is a product brand manufactured by Pulse Power and Measurement Ltd (PPM).

ViaLite Communications is a division of Pulse Power and Measurement Ltd (PPM).

1.1 Typical deployment

A typical system operates as follows.

The ODE-MINI would house a set of FOL TX modules, in a remote outdoor location connected to antenna equipment. **NOTE: deployment must not occur at more than 2000m above sea level.** Antenna electrical signals are input to the transmitter modules, which contain RF signal conditioning and laser control circuitry. The modules modulate the intensity of a beam of light with the RF signal for optical transport over a fibre optic cable.

The light travels through the optical fibres to corresponding receiver modules. The distance between transmitter and receiver can range from 1 m to 100 km; distance in excess of 100 km can be achieved with more complex optical transport systems, depending on the system specified.

The receiver module converts the modulated light back into an electrical signal, which is available at its output.

1.2 ViaLiteHD compatibility

The RF and optical interfaces are compatible with all **ViaLiteHD** Blue modules.

Contact **ViaLite Communications** or your local **ViaLite** agent for more details.

1.3 Care of fibre optic connectors

When the fibre optic cables are not connected, it is essential that the cable and equipment connectors are protected by the dust caps provided with the system. Failure to do so may result in damage to the fibre ends, which are critical to the system performance. Please refer to section 1.4 for fibre optic cable handling details.

1.4 **Fibre optic cable & connectors**

1.4.1 **Connector and cable types**

All **ViaLiteHD** RF modules use singlemode (9µm/125µm) cable terminated in a range of optical connectors detailed below. Cross-site fibre optic cables are available from **ViaLite Communications** as either standard patch leads or heavy-duty multicore cables.



Warning!

Angle polished (APC) and standard (PC) connector must not be confused. The two connector types are not interchangeable and mating one with the other will damage both the cable and the module connectors.

The specification of optical connector is critical to the performance of the complete fibre optic link. System performance can only be guaranteed with fibre optic cables and connectors supplied by **ViaLite Communications**. When FC/APC connectors are specified they must be “narrow key width”.

1.4.2 **Connecting and disconnecting**

Before connecting optical fibres to the module or to each other, ensure that the mating connectors are clean (see below).

1.4.3 **Cleaning optical connectors, cleaning before every use**

Optical connectors **MUST** be cleaned before use, even where they have been protected with dust caps. A large percentage of performance issues can be attributed to dirty fibres.

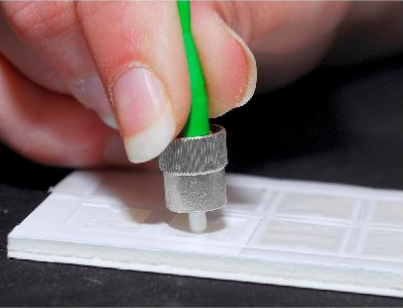

- Peel the plastic cover from an unused “N” cleaning pad.
- Hold the connector between your thumb and forefinger
- Clean the connector using firm pressure by swiping in a pendulum motion through each segment of the “N” shape, following the diagram
- Do not swipe over the same space twice.

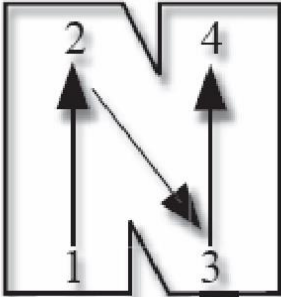

For more details please read the cleaning instruction which accompanies the connector cleaning kit.

1.4.4 **Cleaning optical connectors, high levels of contamination**

If there are performance issues that are not resolved by basic cleaning in section 1.4.3, then the following procedure should be used. If the level of contamination is high it will be necessary to repeat this procedure.

Cleaning items required

- Lint free fibre cleaning tissues and/or cleaning sticks (normal cosmetic tissues produce dust and are not acceptable).
- Reagent grade Iso Propyl Alcohol (IPA).
- Air duster or filtered compressed air line.

Cable Connector Cleaning

- Dampen a patch of cleaning tissue with IPA and clean all surfaces of the plug ferrule.
- Using a dry cleaning tissue, dry the ferrule and clean the end face.
- Using the air duster, blow away any residue from the end of the connector.

Module Female Receptacle Cleaning (only recommended if problems are being experienced)

- Either use an optical cleaning stick or twist a cleaning tissue to form a stiff probe, moisten either with IPA. Gently push the probe into the receptacle and twist around several times to dislodge any dirt.
- Repeat the above process with a dry tissue.
- Using the air duster, blow away any residue from the receptacle.

Important Notes

- IPA is flammable. Follow appropriate precautions / local guidelines when handling and storing.
- IPA can be harmful if spilt on skin. Use appropriate protection when handling.
- It should only be necessary to clean the female receptacles on the modules if problems are being experienced.



Never inspect an optical fibre or connector with the naked eye or an instrument unless you are convinced that there is no optical radiation being emitted by the fibre. Remove all power sources to all modules, and completely disconnect the optical fibres.

1.4.5 SC/APC Connectors

To connect SC/APC optical connectors follow these steps:

- Remove the plug protective cover.
- Align the connector keyway slot in the adaptor to the key of the plug.
- Gently push the plug-into the adaptor until a click is heard and the connector locks.

To disconnect follow these steps:

- Grip the body of the plug and gently pull the plug from the adaptor, replace the protective cover.

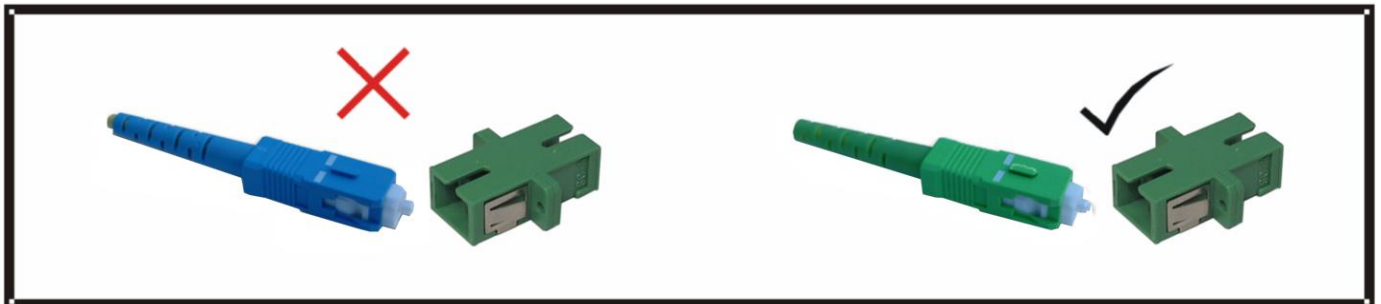

Only connect SC/APC cable to SC/APC.

1.4.6 Minimum bend radius

Because optical fibre is made of glass, it is important not to subject it to excessive stress. For this reason, each type of cable has a minimum bend radius (MBR) specification, beyond which the cable cannot be bent without permanent damage occurring.

The minimum bend radius (MBR) of fibre optic cable fitted to **ViaLite** modules is 50mm. MBR specifications for **ViaLite Communications** supplied fibre optic cables are given in the **ViaLiteHD** RF Link Handbook.

2 Setting up the ODE-MINI

This section describes the connections between your ODE-MINI and external systems and steps that must be taken to set it up. Your ODE-MINI should be delivered preconfigured and ready, but will require connections to external services. This will generally require that you take the following steps:

- Mount the ODE-MINI and the patch box in the required locations
- Terminate the fibre connections within the patch box
- Terminate the RF connections at the ODE-MINI base plate
- Terminate the input power at the ODE-MINI base plate.

2.1 ODE-MINI external features

The ODE-MINI is closed via four M4 screws; this can be torqued with a 4mm AF hexagonal key. The rear provides fixing points for mounting the unit to either a wall mount plate or a pole mounting kit. The unit may also be fitted with a solar shield; this is advisable for any application where there may be significant solar gain.

70002-MINI	Wall mount plate for 75010 Outdoor Enclosure, Kit & Fixings
70004-XXXMINI	Pole mounting kit, pole diameter XXX (diameters range from 15 – 168 mm)
27520	Lightning Suppressor Kit for Outdoor Enclosure, 1 required per RF Channel

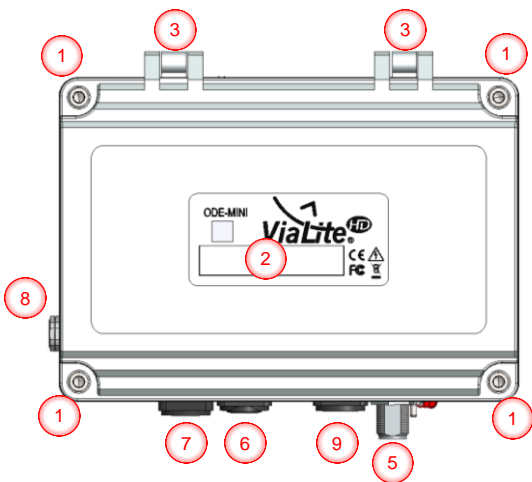

Front view

1. Lid securing screws
2. Serial/Part Number
3. Hinges
4. Securing points for mounting hardware
5. RF Connections
6. Power connection
7. Duo/Quad Fibre connection
8. Gore Vent
9. RJ45 Management Connection

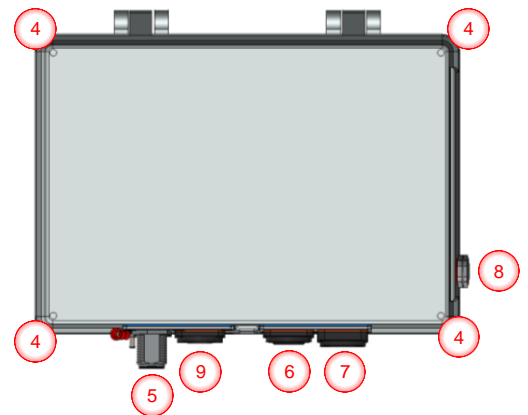

Rear view

2.1.1 Humidity control/ventilator gland

The enclosure incorporates a side mounted vent that allows the air pressure inside the enclosure to equalise with the external environment. Furthermore, it allows excess humidity to leave the enclosure whilst preventing moisture from entering.

Upon installation and sealing of the enclosure, this vent facilitates a stable low pressure differential to ease stress on the seals and a natural continual drying of the internal humidity for improved reliability of the electronics.

It is important to not obstruct / remove or repurpose the vent gland.

2.2 **Weatherproof interface connections**

To maintain the enclosure's IP rating, you should observe the following:

- The front door should be closed and screws tightened.
- All glands should be compressed on to either a cable or blanking rod.
- All connectors should be mated to either a matching half or suitable sealing dust cap.

2.3 **Mounting the ODE-MINI**

2.3.1 **Using the 70004-2 wall mounting bracket kit**

To wall mount your enclosure follow these steps:

- Drill holes in wall/ panel as per dimensions in drawing.
- Mount screws/ fixing hardware into wall.
- Slide Outdoor Enclosure/ Wall Bracket onto position using the keyhole slots.
- Once on wall, tighten fixing hardware to ensure assembly is firmly held in situ.

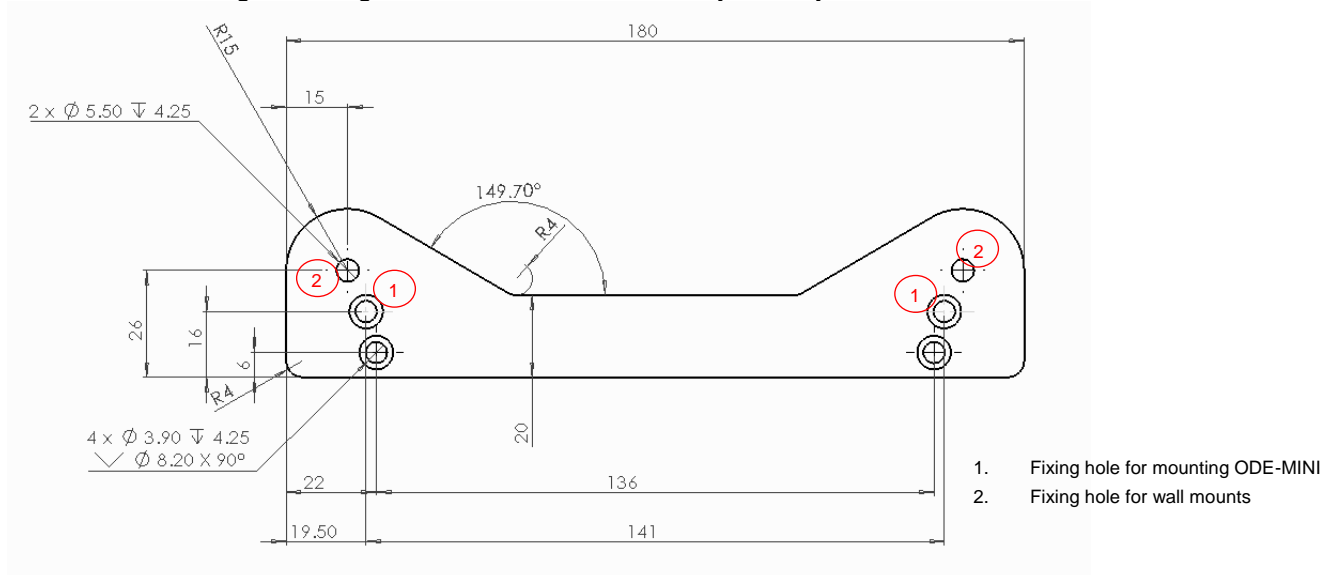

2.3.2 **Using the 70004-(60MINI) (90MINI) (110MINI) pole mounting kit**

The pole mounting kit comes with installation instructions, see section 2.1, that shows the range of pole mounting kits available and the pole sizes onto which they fit.

To pole mount your enclosure follow these steps:

- Mount the long length of unistrut centrally to the top of the ODE-MINI using the supplied washers and screws (small).
- Mount the short length of unistrut centrally to the bottom of the ODE-MINI using the supplied washers and screws (small).
- Slide one unistrut nut into the top and one into the bottom.
- Wrap the pole with the pipe grommet, in the top position.
- Slide one end of the clamp into the top unistrut channel.
- Torque the screw (large) and supplied washers to the unistrut nut in the top channel.
- Wrap the pole with the pipe grommet, in the bottom position.
- Slide one end of the clamp into the bottom unistrut channel.
- Torque the screw (large) and supplied washers to the unistrut nut in the bottom channel.
- Ensure all screws are tight and the mounting is secure.

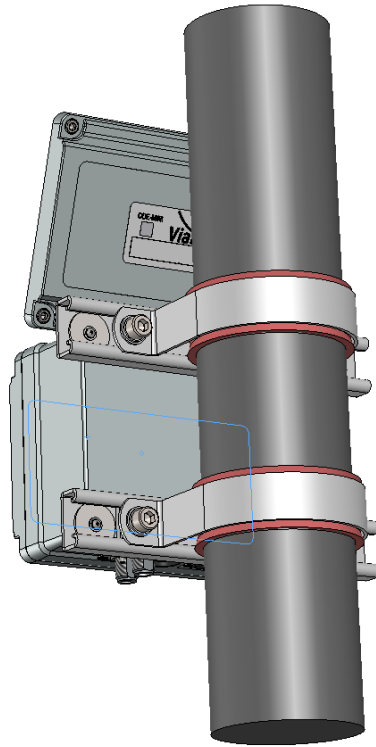

2.4 Lightning Suppressor

There are a number of options available to protect your enclosure and equipment from electromagnetic pulses. Each suppressor will protect a single RF channel. The larger 70006 suppressor has a grounding fixing (M8) on the suppressor, this should be used to achieve maximum protection. The standard options are:

27520 Lightning Suppressor Kit for Outdoor Enclosure, 1 required per RF Channel

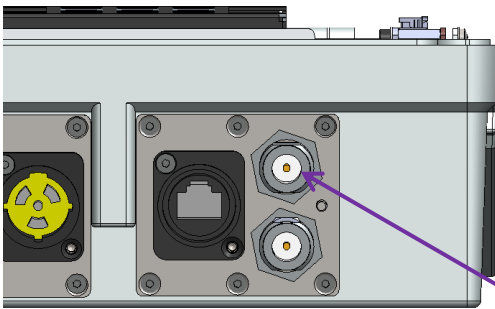

Lightning Suppressors

When fitting a lightning suppressor, first fit the 0.5 m cable to the N-Type on the ODE-MINI.

Fit the N-Type adaptor to the cable. Then fit the lightning suppressor to the adaptor on the cable.



2.5 Antennas

A range of GPS antennas are available that are compatible with the ODE-MINI. A selection are shown below.

- 70005 GPS marine active antenna, 5 dBi plus 28 dB amplifier.
- 70040 GPS active antenna, 3.5 dBi plus 50 dB amplifier.



70005, 33 dBi
Gain antenna



70040, 53.5 dBi
Gain antenna

2.6 Termination of RF Connections

The main enclosure terminates the RF input/output via N-Type female connections located on its baseplate. N-Type connectors are available in both 50 and 75 ohm variants. 50 ohm N-Types are used in the majority of applications, though if 75 ohm connectors are fitted, you **MUST** ensure that both halves are the same impedance; mating dissimilar connectors will cause permanent physical damage.



- RF inputs and outputs should not be exposed to DC voltage levels in excess of ± 36 V.
- Absolute maximum no damage RF input level is nominally +13 dBm (some units may tolerate more power, please see module handbook).

Some transmitter modules are pre-configured to have a DC voltage present on the RF input connector to power low noise amplifiers and similar equipment. All receiver modules will create up to 2 V peak DC transient from the RF output at start up into a 50 Ω load (approximately 5 V into a 1 M Ω load). This may cause failure in some very sensitive equipment.

All modules that have AC coupled inputs and/or outputs will be sensitive to large transients (>5V) applied to either input or output. This may result in permanent damage to the units, particularly to low frequency units. Some receiver modules are equipped with DC loads on their outputs; please see the module handbook. Contact **ViaLite Communications** for more details.

2.7 Termination of power

The ODE-MINI enclosure receives power via a NEUTRIK NAC3 power connector. The male connector is fitted to the left hand gland plate and the cable mounting free female is supplied for on-site termination.

For AC connection connect LIVE/NEUTRAL/EARTH as labelled. The supplied mating half is:

NAC3FX-W Female Black, Yellow 2P+E Power Connector Mains 20A Socket Cable Mount, 250 V ac Polyamide.



This equipment must be earthed in accordance with the local codes. Incomplete or incorrect earthing will cause a safety hazard. The incoming power cable must have a diameter between 6 and 12 mm to be correctly retained by the connector. The electrical conductor cross sectional area should be within the range of 1 - 2.5 mm² to ensure sufficient current handling of up to 2 Amps. This equipment is not intended for direct connection to building installation wiring; ensure connection is via an overcurrent protection breaker and/or residual current device.

Ensure that the power cable is isolated and no power is present during installation. Follow the steps below to fit the power connector

- A** Insert cable into the bushing and housing.

Note: "Apply cable pulling lubricant to cable jacket."

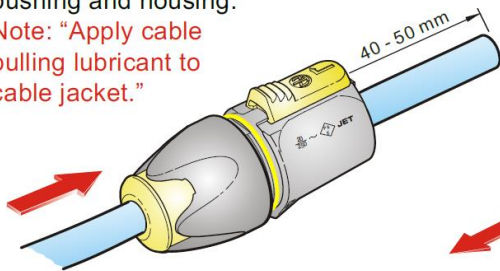

- B** Separate the housing from the bushing (cable remain in bushing)

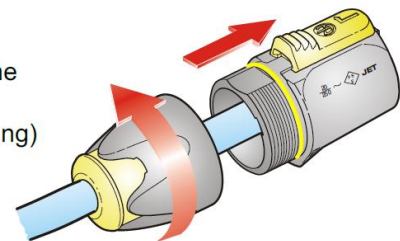

- C** Place chuck over the cable.

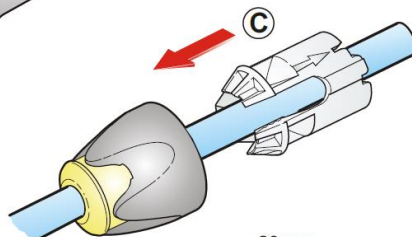

- D** Prepare cable as shown.

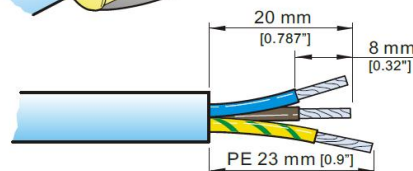

VDE (EN 60320-1/EN60320-2-2)

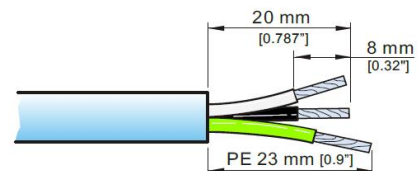

UL (UL 498 / CSA C22.2 No. 182.3)

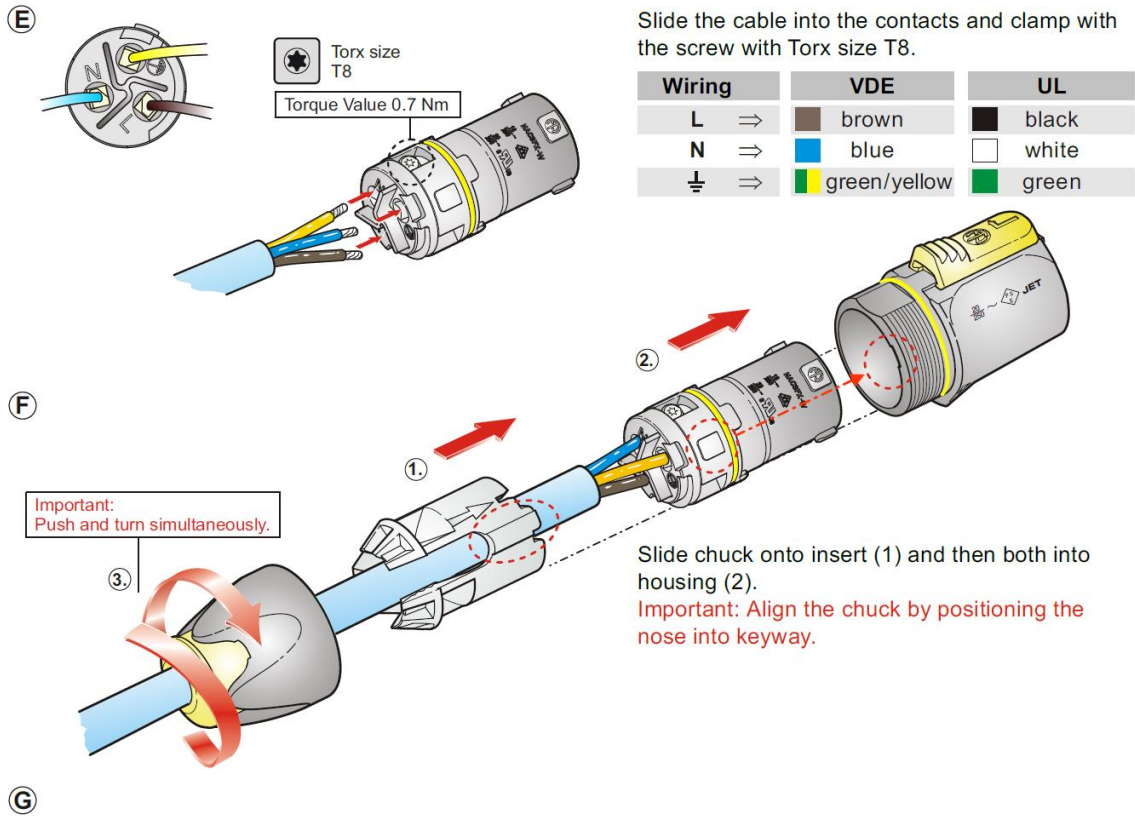

2.8 Termination of Optical fibre

The optical fibre can be terminated in the following optional patch box (5488X). As standard, the patch cable presents SC/APC connections to the end user within the patch box as shown in the picture below. Options to terminate in LC/APC or FC/APC are available.

A kit of additional parts and adapters is supplied with the patch box to allow the customer to tailor their installation on site.

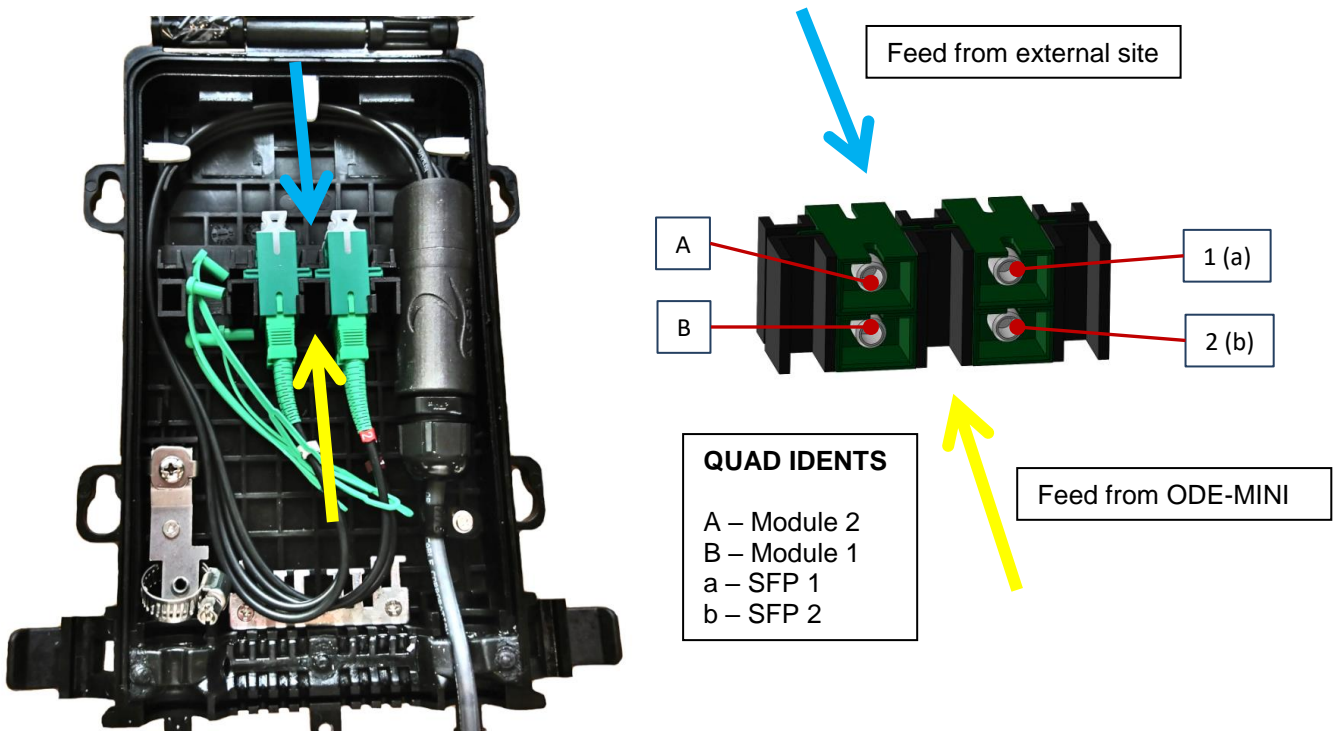

ODE-MINI, internal features

The internals of the ODE-MINI are presented as follows:

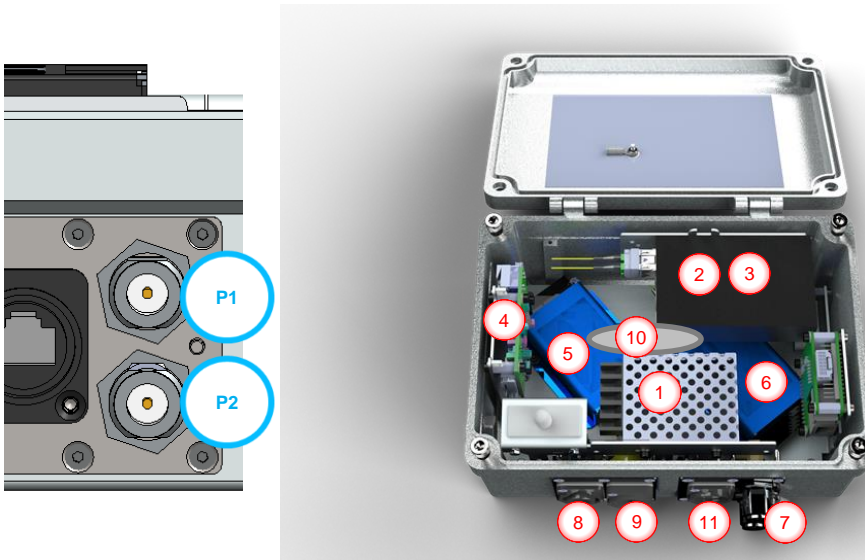

- 1) Primary PSU
- 2) Media Converter
- 3) Secondary PSU Position
- 4) LNB Voltage Selector
- 5) Module 1
- 6) Module 2
- 7) RF Connection(s)
- 8) Optical connector
- 9) Power Connector
- 10) Fuse
- 11) Management RJ45 port

INTERNAL CONNECTION VIEW
 FIBRE TYPE: LC/APC ONLY
 REAR VIEW SHOWN BELOW

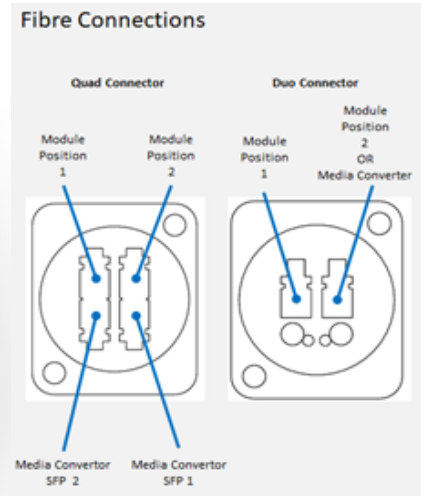

FIBRE CONNECTOR FRONT
 VIEW SHOWN BELOW



The top section houses the dual power supplies which sit directly above the power distribution bar. Within this bar are the power sharing electronics to support the redundant power supply feature and the LNB voltage generator. LEDs indicating the presence and state of each PSU module are presented to aid both installation and diagnostic processes. A replaceable fuse is present also.

The main module bay, supports up to 2 **ViaLiteHD** blue or yellow modules or a single purple module.

Standard layout is TX in slot 1 and RX in slot 2. Item 5 in the list above - Module 1 - is usually TX, and item 6 - Module 2 – is usually RX.

Connect RJ45 and interrogate the site controller to confirm part numbers, serial numbers and settings (gain etc.).

If using a standard ODE-MINI at both ends of the link, you must ensure your Neutrik cable is a crossover, with the module ports 1 and 2 crossed over and the SFP ports 1 and 2 crossed over.

2.9 LNB Voltage selection

ViaLiteHD Blue modules have the option to pass a voltage via the internal bias T to any connected RF equipment (e.g. LNBs).

There are options for (NONE), (Fixed 12V), (Fixed 48V) and customer variable (13V, 15V, 18V or 24V) as illustrated below.

An option for 13V output is also available. This can be partnered with the customer selectable voltage (usually 18 V) to power LNBs with voltage defining polarisation switching. The user can then operate two optical links, one serving each polarisation from a dual LNB.

2.9.1 LNB Customer variable voltage source

Should your ODE-MINI be fitted with a Customer variable LNB voltage source, the setting is factory set to match the customer requirement prior to shipping, but should it need changing, the following procedure should be performed:



Changes to the Customer variable LNB voltage source should be undertaken by a skilled person. Customers and skilled persons must ensure mains power is disconnected when carrying out this operation.

- Power down the enclosure by isolating and removing the mains input.
- Open the enclosure lid.
- Using a 2.5 mm flat blade screwdriver or small crosshead, adjust the 4 position switch such that its arrow head is pointing toward the desired voltage.
- Re-establish power by switching on the power supply switches.

The customer must ensure that the power requirements of their LNB(s) do not exceed the ODE-MINI power capacity which is labelled internally. To drive external equipment with very high power requirements (e.g. a BUC) the option for dual redundant power supplies can be substituted for a dedicated supply to provide this function which bypasses this selector. See next section (ODE-MINI power supplies) for details.

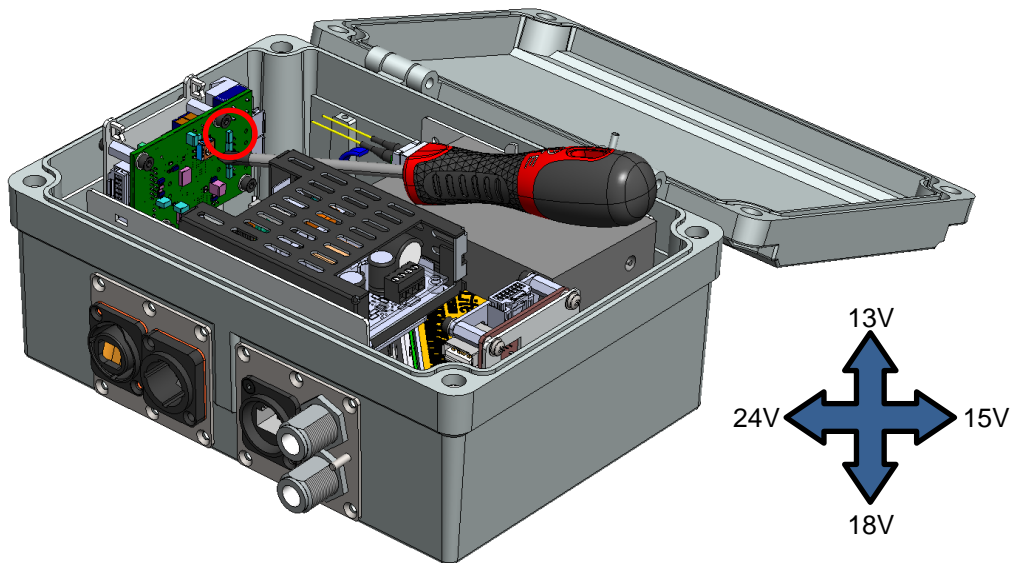

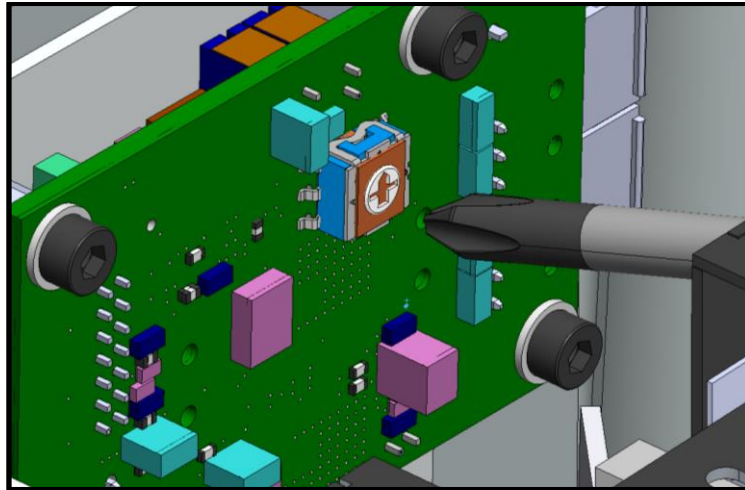

2.9.2 LNB Voltage tolerance

The LNB voltage presented at the RF ports is nominally per the setting, but manufacturing variances have the potential for the following.

LNB Voltage setting	Minimum	Maximum
13	12.6	13.5
15	14.6	15.6
18	17.5	18.8
24	23.3	25.0



WARNING: When connecting any equipment to the RF ports that isn't capable of handling the LNB voltage, ensure a DC block is used to protect it.

2.10 High voltage or high power LNB/BUC supply options

When the on-board variable supply is not suitable for an application, the option for using a dedicated PSU can be considered.

Power supply redundancy for the ODE-MINI is then no longer possible, but the option for 12V or 48V at up to 15 W is possible or even 25 W for temperature environments < 45 Degrees Centigrade.

Please consult with the factory for this arrangement as it will be built to order and there are no customer re-configurable options.

2.11 ODE-MINI power supplies

The ODE-MINI is equipped with internal power supply modules. They are generally used in a dual redundant configuration with identical modules in the left hand (LH) and right hand (RH) positions. It can optionally be equipped with either just a single main PSU module (LH) or with a main PSU (LH) and LNA/BUC PSU (RH). The voltage inputs for the various power supplies' options have the following requirements.

- AC input wide range 100-240 VAC
-

2.12 Replacement of Power Supply Modules

The outdoor housing can be fitted with either one or two power supply modules, the latter provides dual redundant power supply protection for the housing. The power supplies come pre-installed in the outdoor housing. Should it be necessary to replace a power supply module, the procedure is as follows:

- First isolate the unit from the mains power inlet by switching the power isolation switch adjacent to the unit OFF.
- Disconnect the electrical connections between the power supply module and the switch bar.
- Undo the two nuts holding the power supply unit in place. Retain the nuts to refit the new power supply.
- Locate the new module on the studs on the rear plate. Replace the nuts to hold the power supply module in place.
- Reconnect the electrical connector between the power supply module and the switch bar.
- Apply power by switching the power isolation switch ON.

2.13 ODE-MINI replaceable fuse

The incoming power to the ODE-MINI is protected by a common replaceable fuse. This is fitted in-line on the live cable inside the ODE-MINI. Details of this fuse - if different to the standard fuse - are given in your custom handbook.

- Standard replaceable fuse 1 A, 250 V, anti-surge, 20 x 5mm, PPM part number 57117, please check before replacing.

To replace the fuse, the procedure is as follows:

- First isolate the unit from the mains power inlet by unplugging the mains power lead.
- Unscrew the fuse holder by hand.
- Remove the failed fuse from the fuse holder and replace with your new fuse.
- Screw the fuse holder back together.
- Apply power by switching the power isolation switches ON.

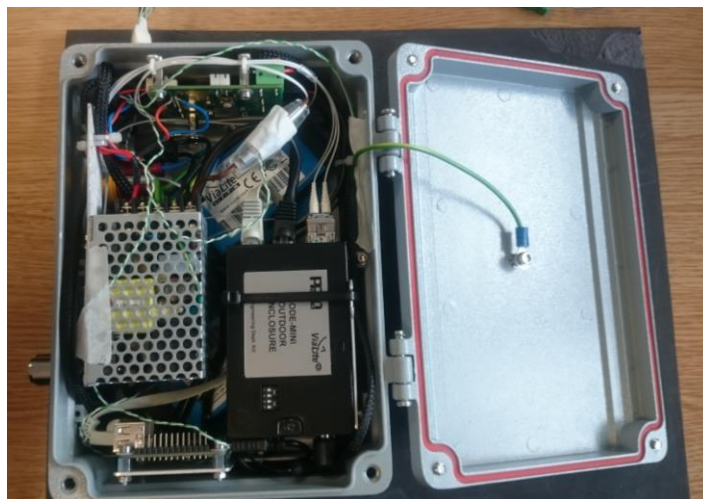

3 Product warranty

The guarantee / warranty period, unless otherwise agreed in writing, shall be as stated in document F292 - PPM Manufactured Product – Warranty, which is available at: <https://ppm.co.uk/warranty-periods/>. Extended warranty options are available at the time of purchase.

Prior to returning any goods for warranty or non-warranty repairs please contact PPM / **ViaLite Communications** for a returns reference.

4 **FCC Approval**

Information to the user of **ViaLite** products:

For a Class A digital device or peripheral, the following instructions are furnished to the user. This equipment has been tested and found to comply with the limits for a Class A digital device, pursuant to part 15 of the FCC Rules. These limits are designed to provide reasonable protection against harmful interference when the equipment is operated in a commercial environment. This equipment generates, uses, and can radiate radio frequency energy and, if not installed and used in accordance with the instruction manual, may cause harmful interference to radio communications. Operation of this equipment in a residential area is likely to cause harmful interference in which case the user will be required to correct the interference at his own expense.

© PULSE POWER & MEASUREMENT LTD 2023

NO PART OF THIS DOCUMENT MAY BE REPRODUCED OR TRANSMITTED IN ANY FORM WITHOUT PRIOR WRITTEN PERMISSION.

PULSE POWER & MEASUREMENT LTD (PPM), 65 SHRIVENHAM HUNDRED BUSINESS PARK, SWINDON, SN6 8TY, UK.

TEL: +44 1793 784389

FAX: +44 1793 784391

EMAIL : SALES@VIALITE.COM

WEBSITE : WWW.VIALITE.COM